



UNIVERSIDAD
NACIONAL DE CUYO



FACULTAD DE INGENIERIA
en acción continua...

Facultad de Ingeniería – Universidad Nacional de Cuyo

Asignatura: Mecánica de los Fluidos

Compilado de Tablas

Fuentes:

- Green, Don W., PERRY'S CHEMICAL ENGINEERS' HANDBOOK 8º EDITION, ISBN 0-07-159313-6
- Liu, Henry., Pipeline engineering, 2005, ISBN 0-203-59487-8
- White, Frank M., Fluid Mechanics, Fourth Edition
- Dulhoste, Jean-François, Escuela de Ingeniería Mecánica, ULA

UNIDADES Y CONVERSIONES

TABLA 1. Unidades inglesas, unidades SI y factores de conversión

Cantidad	Unidades inglesas	Sistema internacional (SI)	Factor de conversión
Longitud	pulgada	milímetro	1 in = 25.4 mm
	pie	metro	1 ft = 0.3048 m
	milla	kilómetro	1 milla = 1.609 km 1 milla = 5280 ft
	yarda		1 milla = 1760 yd
Área	Pulgada cuadrada	Centímetro cuadrado	1 in ² = 6.452 cm ²
	Pie cuadrado	metro cuadrado	1 ft ² = 0.09290 m ²
Volumen	pulgada cúbica	centímetro cúbico	1 in ³ = 16.39 cm ³
	pie cúbico	metro cúbico	1 ft ³ = 0.02832 m ³
	Galón(US o Brit)		1 gal(US) = 231 in ³ = 0.003789 m ³ 1 gal (Brit) = 1.2 gal (US)
Masa	libra-masa,	kilogramo	1 lbm = 0.4536 kg
	slug		1 slug = 14.59 kg
	onza		1 oz = 28.35x10 ⁻³ Kg
Densidad	slug/pie cúbico	kilogramo/metro cúbico	1 slug/ft ³ = 515.4 kg/m ³
Fuerza	libra-fuerza	newton	1 lb = 4.448 N
Trabajo	pie-libra	newton-metro	1 ft-lb = 1.356 N-m
Presión	libra/pulgada cuadrada	newton/metro cuadrado (pascal)	1 psi = 6895 Pa
	libra/pie cuadrado		1 psf = 47.88 Pa
		Bar	1 bar = 10 ⁵ Pa = 14.7 psi
	Pulgada de mercurio		1 psi = 2.036 in Hg
	Pulgada de agua		1 psi = 27.7 in H ₂ O
Temperatura	grado Fahrenheit	grado Celsius	°F= 9/5 °C+32
	grado Rankine	kelvin	°R = 9/5 °K
Energía	unidad térmica británica (BTU)	joule	1 Btu = 1055 J
	caloría		1 cal = 4.186 J
	pie-libra		1 ft-lb = 1.356 J 1 BTU = 778.2 ft-lb
Potencia	caballo de fuerza	watt	1 hp = 745.7 W
	pie-libra/segundo		1 ft-lb/s = 1.356 W
Velocidad	pie/segundo	metro/segundo	1 ft/s = 0.3048 m/s
	Milla/hora		1 mph = 1.467 ft/s
Aceleración	pie/segundo al cuadrado	metro/segundo al cuadrado	1 ft/s ² = 0.3048 m/s ²
Frecuencia	ciclo/segundo	hertz	1 cps = 1.000 Hz
Viscosidad	libra-segundo/pie cuadrado	newton-segundo/metro al cuadrado	1 lb-s/ft ² = 47.88 N.s/m ²
		Stoke	1 stoke = 10 ⁻⁴ m ² /s
		Poise	1 poise = 0.1 N-s/m ²

J. Factores de Conversión

<i>Magnitud</i>	Unidad Inglesa	Unidad S.I.	Símbolo	Unidades equivalentes
<i>Longitud</i>	1 pie	= 0.3048 metros	m	–
<i>Masa</i>	1 slug	= 14.59 kilogramos	kg	–
<i>Tiempo</i>	1 segundo	= 1.0 segundo	s	–
<i>Fuerza</i>	1 libra (lb)	= 4.448 newtons	N	kg · m/s ²
<i>Presión</i>	1 lb/pulg ²	= 6895 pascales	Pa	N/m ² ó kg/m · s ²
<i>Energía</i>	1 lb-pie	= 1.356 julios	J	N · m ó kg · m ² /s ²
<i>Potencia</i>	1 lb-pie/s	= 1.356 vatios	W	J/s

<i>Longitud</i>	
1 pie = 0.3048 m	1 km = 1000 m
1 pulg = 25.4 mm	1 cm = 10 mm
1 mi = 5280 pie	1 m = 1000 mm
1 mi = 1.609 km	
<i>Área</i>	
1 pie ² = 0.0929 m ²	1 m ² = 10.76 pies ²
1 pulg ² = 645.2 mm ²	1 m ² = 10 ⁶ mm ²
<i>Volumen</i>	
1 pie ³ = 7.48 gal	1 gal = 0,003 79 m ³
1 pie ³ = 1728 pulg ³	1 gal = 3.785 L
1 pie ³ = 0.0283 m ³	1 m ³ = 1000 L
	1 galón imperial = 1.201 gal (EUA)
<i>Velocidad de flujo de volumen</i>	
1 pie ³ /s = 449 gal/min	1 gal/min = 3.785 L/min
1 pie ³ /s = 0.0283 m ³ /s	1 L/min = 16.67 × 10 ⁻⁶ m ³ /s
1 gal/min = 6.309 × 10 ⁻⁵ m ³ /s	1 m ³ /s = 60 000 L/min
<i>Temperatura</i>	
$T(^{\circ}\text{C}) = [T(^{\circ}\text{F}) - 32] \frac{5}{9}$	<i>Presión</i>
$T(^{\circ}\text{F}) = \frac{9}{5} [T(^{\circ}\text{C})] + 32$	1 bar = 100 kPa
	1 bar = 14.50 lb/pulg ²
<i>Densidad</i>	
1 slug/pie ³ = 515.4 kg/m ³	<i>Energía</i>
	1 lb-pie = 1.356 J
	1 Btu = 1.055 kJ
	1 W-h = 3.600 kJ
<i>Peso específico</i>	
1 lb/pie ³ = 157.1 N/m ³	
<i>Potencia</i>	
1 hp = 550 lb-pie/s	1 lb-pie/s = 1.356 W
1 hp = 745.7 W	1 Btu/h = 0.293 W

PROPIEDADES DE FLUIDOS

TABLA 2. Propiedades del agua

Unidades SI

Temperatura (°C)	Densidad ρ (kg/m ³)	Viscosidad μ (N - s/m ²)	Viscosidad cinemática ν (m ² /s)	Tensión superficial σ (N/m)	Presión de vapor (kPa)	Módulo de volumen B (Pa)
0	999.9	1.792 x 10 ⁻³	1.792 x 10 ⁻⁶	0.0762	0.610	204 x 10 ⁷
5	1000.0	1.519	1.519	0.0754	0.872	206
10	999.7	1.308	1.308	0.0748	1.13	211
15	999.1	1.140	1.141	0.0741	1.60	214
20	998.2	1.005	1.007	0.0736	2.34	220
30	995.7	0.801	0.804	0.0718	4.24	223
40	992.2	0.656	0.661	0.0701	3.38	227
50	988.1	0.549	0.556	0.0682	12.3	230
60	983.2	0.469	0.477	0.0668	19.9	228
70	977.8	0.406	0.415	0.0650	31.2	225
80	971.8	0.357	0.367	0.0630	47.3	221
90	965.3	0.317	0.328	0.0612	70.1	216

Unidades inglesas

Temperatura (°F)	Densidad (slug/ft ³)	Viscosidad (lb-s/ft ²)	Viscosidad cinemática (ft ² /s)	Tensión superficial (lb/ft)	Presión de vapor (psi)	Módulo de volumen (psi)
32	1.94	3.75 x 10 ⁻⁵	1.93 x 10 ⁻⁵	0.518 x 10 ⁻²	0.089	293 000
40	1.94	3.23	1.66	0.514	0.122	294 000
50	1.94	2.74	1.41	0.509	0.178	305 000
60	1.94	2.36	1.22	0.504	0.256	311 000
70	1.94	2.05	1.06	0.500	0.340	320 000
80	1.93	1.80	0.93	0.492	0.507	322 000
90	1.93	1.60	0.83	0.486	0.698	323 000
100	1.93	1.42	0.74	0.480	0.949	327 000
120	1.92	1.17	0.61	0.465	1.69	333 000
140	1.91	0.98	0.51	0.454	2.89	330 000
160	1.90	0.84	0.44	0.441	4.74	326 000
180	1.88	0.73	0.39	0.426	7.51	318 000
200	1.87	0.64	0.34	0.412	11.53	308 000
212	1.86	0.59 x 10 ⁻⁵	0.32 x 10 ⁻⁵	0.404 x 10 ⁻²	14.7	300000

TABLA 3. Propiedades del aire a presión atmosférica**Unidades SI**

Temperatura (°C)	Densidad ρ (kg/m ³)	Viscosidad μ (N - s/m ²)	Viscosidad cinemática ν (m ² /s)	Velocidad del sonido c (m/s)
-50	1.582	1.46 x 10 ⁻⁵	0.921 x 10 ⁻⁵	299
-30	1.452	1.56	1.08 x 10 ⁻⁵	312
-20	1.394	1.61	1.16	319
-10	1.342	1.67	1.24	325
0	1.292	1.72	1.33	331
10	1.247	1.76	1.42	337
20	1.204	1.81	1.51	343
30	1.164	1.86	1.60	349
40	1.127	1.91	1.69	355
50	1.092	1.95	1.79	360
60	1.060	2.00	1.89	366
70	1.030	2.05	1.99	371
80	1.000	2.09	2.09	377
90	0.973	2.13	2.19	382
100	0.946	2.17	2.30	387
200	0.746	2.57	3.45	436
300	0.616	2.93 x 10 ⁻⁵	4.75 x 10 ⁻⁵	480

Unidades inglesas

Temperatura (°F)	Densidad (slug/ft ³)	Viscosidad (lb-s/ft ²)	Viscosidad cinemática (ft ² /s)	Velocidad del sonido (ft/s)
-20	0.00280	3.34 x 10 ⁻⁷	11.9 x 10 ⁻⁵	1028
0	0.00268	3.38	12.6	1051
20	0.00257	3.50	13.6	1074
40	0.00247	3.62	14.6	1096
60	0.00237	3.74	15.8	1117
68	0.00233	3.81	16.0	1125
80	0.00228	3.85	16.9	1138
100	0.00220	3.96	18.0	1159
120	0.00213	4.07	18.9	1180
160	0.00199	4.23	21.3	1220
200	0.00187	4.50	24.1	1258
300	0.00162	4.98	30.7	1348
400	0.00144	5.26	36.7	1431
1000	0.000844	7.87 x 10 ⁻⁷	93.2 x 10 ⁻⁵	1839

TABLA 4. Propiedades de la atmósfera estándar**Unidades SI**

Altitud (m)	Temperatura (°K)	Presión (KPa)	Densidad (Kg/m³)	Velocidad del sonido (m/s)
0	288.2	101.3	1.125	340
500	284.9	95.43	1.167	338
1000	281.7	89.85	1.112	336
2000	275.2	79.48	1.007	333
4000	262.2	61.64	0.81194	325
6000	249.2	47.21	0.6602	316
8000	236.2	35.65	0.5258	308
10000	223.3	26.49	0.4136	300
12000	216.7	19.40	0.3119	295
14000	216.7	14.17	0.2278	295
16000	216.7	10.35	0.1665	295
18000	216.7	7.563	0.1216	295
20000	216.7	5.528	0.0889	295
30000	226.5	1.196	0.0184	302
40000	250.4	0.287	4.00x10 ⁻³	317
50000	270.7	0.0789	1.03x10 ⁻³	330
60000	255.8	0.0225	3.06x10 ⁻⁴	321
70000	219.7	0.00551	8.75x10 ⁻⁵	297
80000	180.7	0.00103	2.00x10 ⁻⁵	269

Unidades inglesas

Altitud (ft)	Temperatura (°F)	Presión (lb/ft²)	Densidad (slugs/ft³)	Velocidad del sonido (ft/s)
0	59.0	2116	0.00237	1117
1 000	55.4	2014	0.00231	1113
2000	51.9	1968	0.00224	1109
5 000	41.2	1760	0.00205	1098
10 000	23.4	1455	0.00176	1078
15 000	5.54	1194	0.00150	1058
20 000	-12.3	973	0.00127	1037
25 000	-30.1	785	0.00107	1016
30 000	-48.0	628	0.000890	995
35 000	-65.8	498	0.000737	973
36 000	-67.6	475	0.000709	971
40 000	-67.6	392	0.000586	971
50 000	-67.6	242	0.000362	971

TABLA 5. Propiedades de los gases ideales a 300 °K

Gas	Fórmula Química	Masa molar	R		C _P		k
			Ft-lb/slug-°R	KJ/Kg-°K	Ft-lb/slug-°R	Kj/Kg-°K	
Aire	-	28.97	1 716	0.287	6 012	1.004	1.40
Argón	Ar	39.94	1 244	0.2081	3 139	0.5203	1.667
Dióxido de carbono	CO ₂	44.01	1 129	0.1889	5 085	0.8418	1.287
Monóxido de carbono	CO	28.01	1 775	0.2968	6 238	1.041	1.40
Etano	C ₂ H ₆	30.07	1 653	0.2765	10 700	1.766	1.184
Helio	He	4.003	12 420	2.077	31 310	5.193	1.667
Hidrógeno	H ₂	2.016	24 660	4.124	85 930	14.21	1.40
Metano	CH ₄	16.04	3 100	0.5184	13 330	2.254	1.30
Nitrógeno	N ₂	28.02	1 774	0.2968	6 213	1.042	1.40
Oxígeno	O ₂	32.00	1 553	0.2598	5 486	0.9216	1.394
Propano	C ₃ H ₈	44.10	1 127	0.1886	10 200	1.679	1.12
Vapor de agua	H ₂ O	18.02	2 759	0.4615	11 150	1.872	1.33

$$C_V = C_P - R, \quad k = C_P/C_V$$

TABLA 6. Propiedades de líquidos comunes

A presión atmosférica y aproximadamente 60 a 70°F (16 a 21°C)

Líquido	Peso específico		Densidad		Tensión superficial		Presión de vapor	
	γ	γ	ρ	ρ	σ	σ	P_v	P_v
	lb/ft ³	N/m ³	slugs/ft ³	kg /M3	lb/ft	N/m	psia	kPa
Alcohol etílico	49.3	7 744	1.53	789	0.0015	0.022	-	-
Benceno	56.2	8 828	1.75	902	0.0020	0.029	1.50	10.3
Tetracloruro de carbono	99.5	15 629	3.09	1 593	0.0018	0.026	12.50	86.2
Gasolina	42.4	6 660	1.32	680	-	-	-	-
Glicerina	78.6	12 346	2.44	1 258	0.0043	0.063	2 x 10 ⁻⁶	1.4 x 10 ⁻⁵
Queroseno	50.5	7 933	1.57	809	0.0017	0.025	-	-
Mercurio	845.5	132 800	26.29	13 550	0.032	0.467	2.31 x 10 ⁻⁵	1.59 x 10
Aceite SAE 10	57.4	9 016	1.78	917	0.0025	0.036	-	-
Aceite SAE 30	57.4	9 016	1.78	917	0.0024	0.035	-	-
Trementina	54.3	8 529	1.69	871	0.0018	0.026	7.7 x 10 ⁻³	5.31 x 10 ⁻²
Agua	62.4	9 790	1.94	998	0.0050	0.073	0.34	2.34

Tabla 7. Densidades relativas de algunos materiales

Material	Densidad relativa	Líquido	Densidad relativa
Aluminio	2.64	Benceno	0.879
Madera de balsa	0.14	Tetracloruro de carbono	1.595
Latón	8.55	Aceite de ricino	0.969
Hierro fundido	7.08	Petróleo crudo	0.82-0.92
Concreto (curado)	2.4*	Gasolina	0.72
Concreto (líquido)	2.5*	Glicerina	1.26
Cobre	8.91	Heptano	0.684
Hielo (0 C)	0.917	Keroseno	0.82
Plomo	11.4	Aceite lubricante	0.88
Roble	0.77	Mercurio	13.55
Acero	7.83	Octano	0.702
Styrofoam (1 pcf')	0.0160	Agua de mar n	1.025
Styrofoam (3 pcf)	0.0481	Aceite SAE 10W	0.92
Uranio (reducido)	18.7	Agua	0.998
Pino blanco	0.43	Aceite azul de E. V. Hill	0.797
		Aceite rojo Meriam	0.827
		Ftalato de dibutilo	1.04
		Monocloronaftaleno	1.20
		Bromoetilbenceno (azul Meriam)	1.75
		Tetrabromoetano	2.95

* Dependiendo del agregado

Figura 1. Densidades relativas del agua y mercurio

(De R. W. Fox y T. A. McDonald, *Introducción a la Mecánica de Fluidos*, 4a. ed., John Wiley & Sons, Inc., Nueva York, 1995.)



Figura 2. Viscosidad en función de la temperatura.

(De R. W. Fox y T. A. McDonald, *Introducción a la Mecánica de Fluidos*, 4a. ed., John Wiley & Sons, Inc., Nueva York, 1995.)

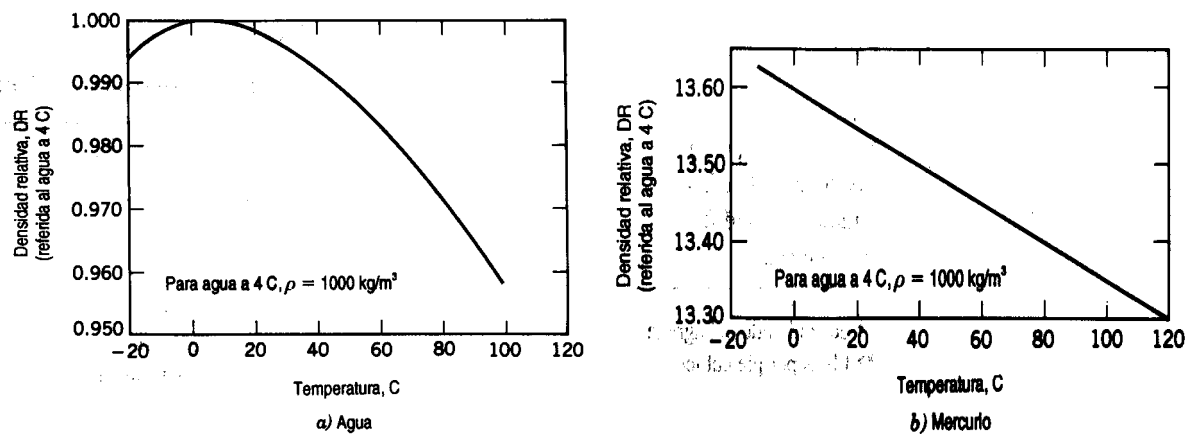

Figura 3. Viscosidad cinemática (a presión atmosférica) en función de la temperatura.

(De R. W. Fox y T. A. McDonald, *Introducción a la Mecánica de Fluidos*, 4a. ed., John Wiley & Sons, Inc., Nueva York, 1995.)

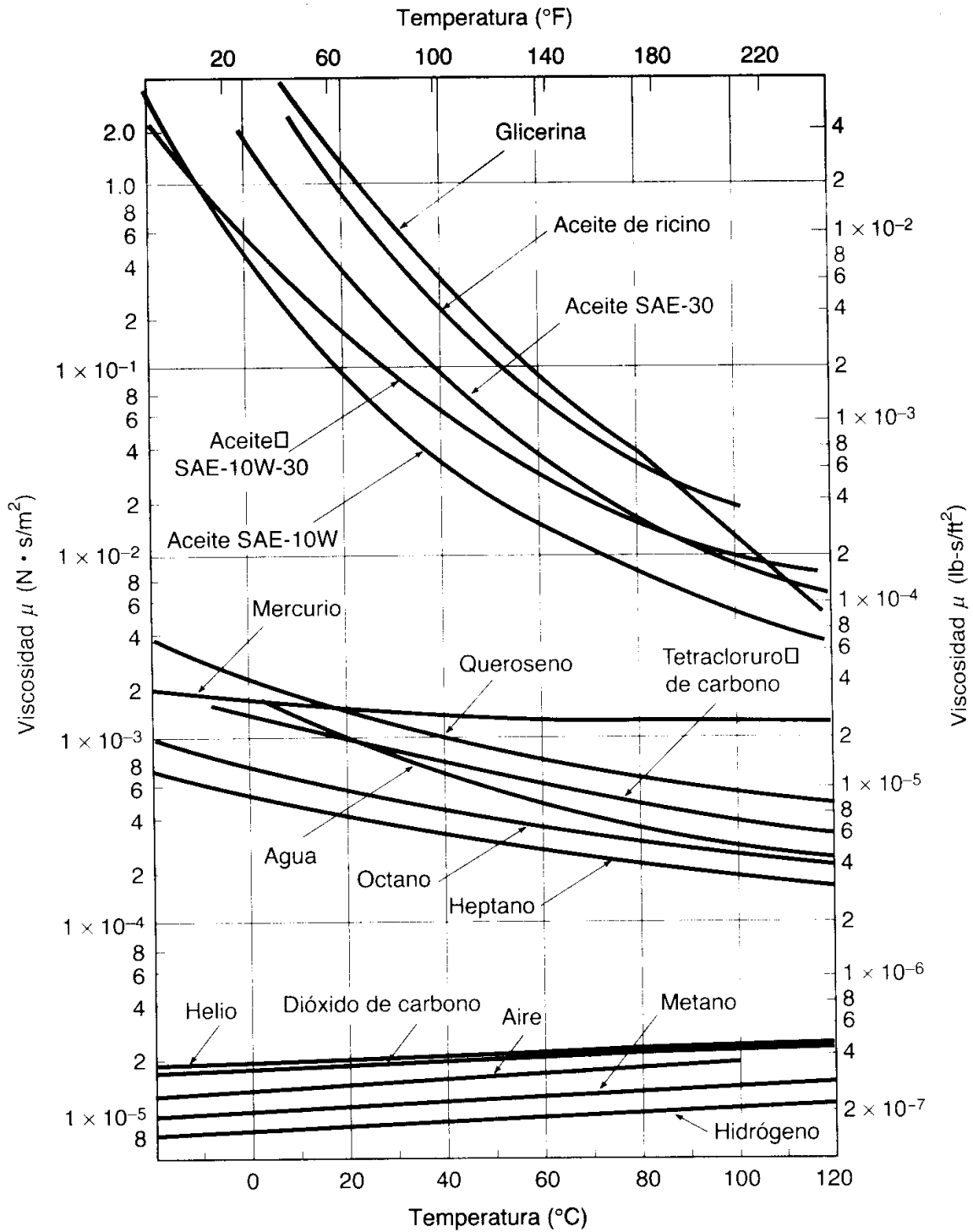
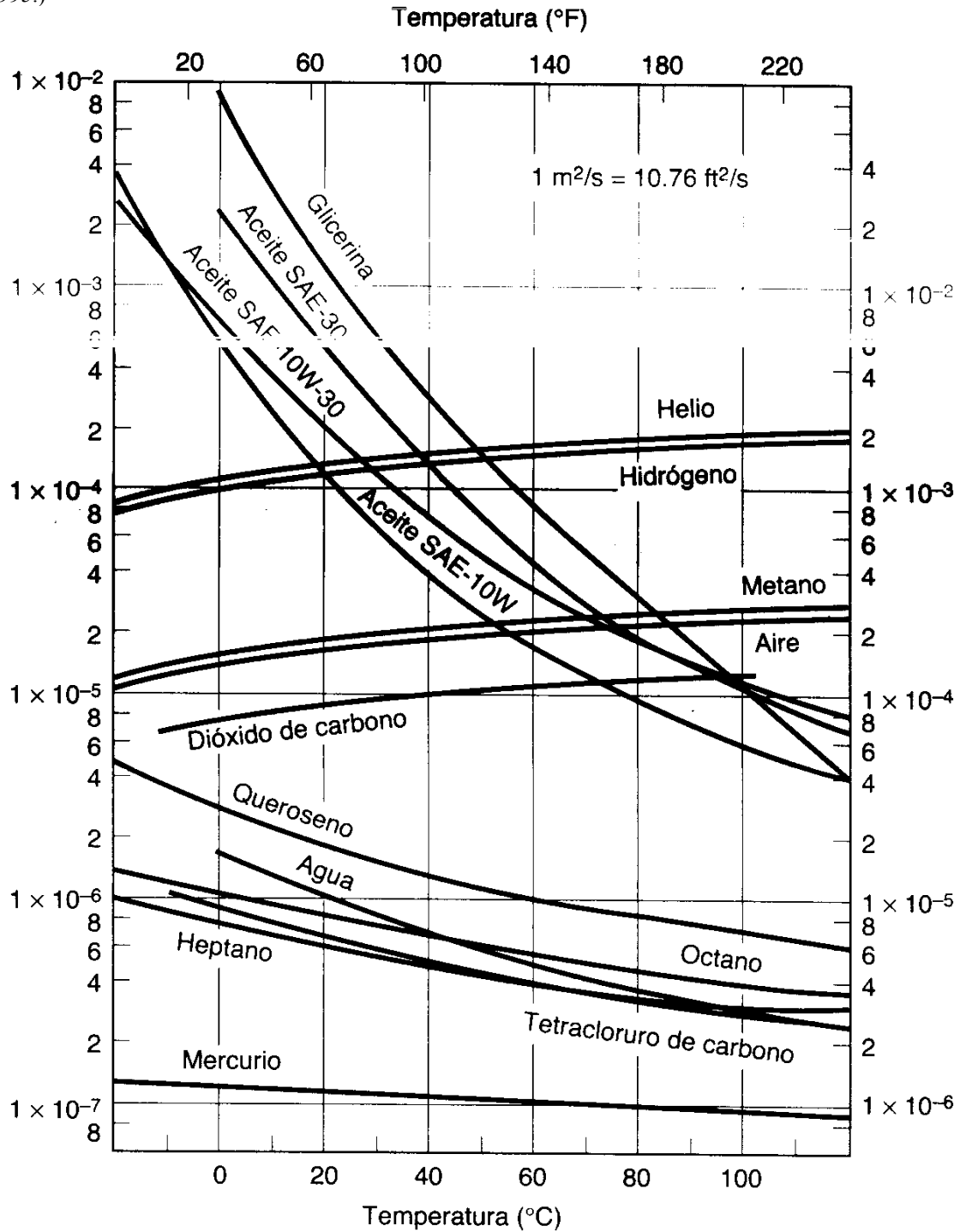

TABLE 1-7 Common Units and Conversion Factors*

Mass (M)	1 pound mass = 453.5924 grams = 0.45359 kilograms = 7000 grains 1 slug = 32.174 pounds mass 1 ton (short) = 2000 pounds mass 1 ton (long) = 2240 pounds mass 1 ton (metric) = 1000 kilograms = 2204.62 pounds mass 1 pound mole = 453.59 gram moles	1 atm = 760 millimeters of mercury at 0°C (density 13.5951 g/cm ³) = 29.921 inches of mercury at 32°F = 14.696 pounds force/square inch = 33.899 feet of water at 39.1°F = 1.01325 × 10 ⁶ dynes/square centimeter = 1.01325 × 10 ⁵ Newtons/square meter
Length (L)	1 foot = 30.480 centimeters = 0.3048 meters 1 inch = 2.54 centimeters = 0.0254 meters 1 mile (U.S.) = 1.60935 kilometers 1 yard = 0.9144 meters	Density (M/L ³) 1 pound mass/cubic foot = 0.01601846 grams/cubic centimeter = 16.01846 kilogram/cubic meter
Area (L ²)	1 square foot = 929.0304 square centimeters = 0.09290304 square meters 1 square inch = 6.4516 square centimeters 1 square yard = 0.836127 square meters	Energy (H or FL) 1 British thermal unit = 251.98 calories = 1054.4 joules = 777.97 foot-pounds force = 10.409 liter-atmospheres = 0.2930 watt-hour
Volume (L ³)	1 cubic foot = 28,316.85 cubic centimeters = 0.02831685 cubic meters = 28.31685 liters = 7.481 gallons (U.S.) 1 gallon = 3.7853 liters = 231 cubic inches	Diffusivity (L ² /θ) 1 square foot/hour = 0.258 cm ² /s = 2.58 × 10 ⁻⁵ m ² /s
Time (θ)	1 hour = 60 minutes = 3600 seconds	Viscosity (M/Lθ) 1 pound mass/foot hour = 0.00413 g/cm s = 0.000413 kg/m s 1 centipoise = 0.01 poise = 0.01 g/cm s = 0.001 kg/m s = 0.000672 lbm/ft s = 0.0000209 lbf _s /ft ²
Temperature (T)	1 centigrade or Celsius degree = 1.8 Fahrenheit degree Temperature, Kelvin = T°C + 273.15 Temperature, Rankine = T°F + 459.7 Temperature, Fahrenheit = 9/5 T°C + 32 Temperature, centigrade or Celsius = 5/9 (T°F - 32) Temperature, Rankine = 1.8 T K	Thermal conductivity [H/θL ² (T/L)] 1 Btu/hr ft ² (°F/ft) = 0.00413 cal/s cm ² (°C/cm) = 1.728 J/s m ² (°C/m)
Force (F)	1 pound force = 444,822.2 dynes = 4.448222 Newtons = 32.174 poundals	Heat transfer coefficient 1 Btu/hr ft ² °F = 5.678 J/s m ² °C
Pressure (F/L ²)	Normal atmospheric pressure	Heat capacity (H/MT) 1 Btu/lbm °F = 1 cal/g °C = 4184 J/kg °C
		Gas constant 1.987 Btu/lbm mole °R = 1.987 cal/mol K = 82.057 atm cm ³ /mol K = 0.7302 atm ft ³ /lb mole °F = 10.73 (lb _f /in. ²) (ft ³)/lb mole °R = 1545 (lb _f /ft ²) (ft ³)/lb mole °R = 8.314 (N/m ²) (m ³)/mol K
		Gravitational acceleration g = 9.8066 m/s ² = 32.174 ft/s ²

NOTE: U.S. customary units, or British units, on left and SI units on right.
 *Adapted from Faust et al., *Principles of Unit Operations*, John Wiley and Sons, 1980.

TABLE 1-8 Kinematic-Viscosity Conversion Formulas

Viscosity scale	Range of t, sec	Kinematic viscosity, stokes
Saybolt Universal	32 < t < 100	0.00226t - 1.95/t
	t > 100	0.00220t - 1.35/t
Saybolt Furoil	25 < t < 40	0.0224t - 1.84/t
	t > 40	0.0216t - 0.60/t
Redwood No. 1	34 < t < 100	0.00260t - 1.79/t
	t > 100	0.00247t - 0.50/t
Redwood Admiralty		0.027t - 20/t
Engler		0.00147t - 3.74/t

TABLE 1-9 Values of the Gas-Law Constant

Temp. scale	Press. units	Vol. units	Wt. units	Energy units*	R	
Kelvin			g-moles	calories	1.9872	
			g-moles	joules (abs)	8.3144	
			g-moles	joules (int)	8.3130	
			g-moles	atm cm ³	82.057	
		atm.	cm ³	g-moles	atm cm ³	0.08205
		atm.	liters	g-moles	atm liters	62.361
		mm. Hg	liters	g-moles	mm Hg-liters	0.08314
		bar	liters	g-moles	bar-liters	0.08478
		kg/cm ²	liters	g-moles	kg/(cm ²)(liters)	1.314
		atm	ft ³	lb-moles	atm-ft ³	998.9
Rankine			lb-moles	mm Hg-ft ³	1.9872	
			lb-moles	chu or pcu	1.9872	
			lb-moles	Btu	0.0007805	
			lb-moles	hp-hr	0.0005819	
			lb-moles	kw-hr	0.7302	
			lb-moles	atm-ft ³	21.85	
		atm	ft ³	lb-moles	in Hg-ft ³	555.0
		in Hg	ft ³	lb-moles	mm Hg-ft ³	10.73
		mm Hg	ft ³	lb-moles	(lb)(ft ³)/in ²	1545.0
		lb/in ² abs	ft ³	lb-moles	ft-lb	

*Energy units are the product of pressure units and volume units.

TABLE C.2
Physical Properties of Certain Liquids at Atmospheric Pressure
(SI Units)

Liquid	Temperature T ($^{\circ}\text{C}$)	Density, ρ (kg/m^3)	Dynamic Viscosity $\mu \times 10^3$ ($\text{N}\cdot\text{s}/\text{m}^2$)	Vapor Pressure $p_v \times 10^{-3}$ (N/m^2 abs.)	Bulk Modulus $E_v \times 10^{-9}$ (N/m^2)
Ethyl alcohol	20	789	1.19	5.9	1.06
Gasoline	16	680	0.31	55	1.3
Glycerin	20	1260	1500	14	4.52
Mercury	20	13,600	1.57	1.6×10^{-4}	28.5
SAE 30 oil	16	912	380	—	1.5
Seawater	16	1030	1.20	1.77	2.34
Water	16	999	1.12	1.77	2.15

TABLE C.3
Physical Properties of Water as a Function of Temperature at
Atmospheric Pressure (ft-lb Units)

Temperature, T ($^{\circ}\text{F}$)	Density, ρ (slug/ft^3)	Dynamic Viscosity, $\mu \times 10^3$ ($\text{lb}\cdot\text{s}/\text{ft}^2$)	Vapor Pressure, P_v (psia)	Bulk Modulus of Elasticity, $E_v \times 10^{-5}$ (psi)	Speed of Sound, C (ft/s)
32	1.940	3.732	0.0885	2.87	4603
40	1.940	3.228	0.122	2.96	4672
50	1.940	2.730	0.178	3.05	4748
60	1.938	2.344	0.256	3.13	4814
70	1.936	2.037	0.363	3.19	4871
80	1.934	1.791	0.507	3.24	4819
90	1.931	1.500	0.698	3.28	4960
100	1.927	1.423	0.949	3.31	4995
120	1.918	1.164	1.692	3.32	5049
140	1.908	0.974	2.888	3.30	5091
160	1.896	0.832	4.736	3.26	5101
180	1.883	0.721	7.507	3.18	5195
200	1.869	0.634	11.52	3.08	5089
212	1.860	0.589	14.69	3.00	5062

TABLE C.4
Physical Properties of Water as a Function of Temperature at Atmospheric Pressure (SI Units)

Temperature, T (°C)	Density, ρ (kg/m ³)	Dynamic Viscosity, $\mu \times 10^4$ (N-s/m ²)	Vapor Pressure, $p_v \times 10^{-4}$ (N/m ²)	Bulk Modulus of Elasticity, $E_v \times 10^{-9}$ (N/m ²)	Speed of Sound, C (m/s)
0	999.9	17.87	0.0611	1.98	1403
5	1000	15.19	0.0872	2.05	1427
10	999.7	13.07	0.123	2.10	1447
20	998.2	10.02	0.234	2.17	1481
30	995.7	7.98	0.424	2.25	1507
40	992.2	6.53	0.738	2.28	1526
50	988.1	5.47	1.233	2.29	1541
60	983.2	4.67	1.992	2.28	1552
70	977.8	4.04	3.116	2.25	1555
80	971.8	3.55	4.734	2.20	1555
90	965.3	3.15	7.010	2.14	1550
100	958.4	2.82	10.13	2.07	1543

TABLE C.5
Physical Properties of Certain Gases at Atmospheric Pressure (ft-lb Units)

Gas	Temperature, T (°F)	Density, $\rho \times 10^3$ (slug/ft ³)	Dynamic Viscosity, $\mu \times 10^7$ (lb-s/ft ²)	Gas Constant, $R \times 10^{-3}$ (ft-lb/slug/°R)	Specific Heat Ratio, k	Specific Heat Capacity, c_v (Btu/lbm/°R)
Air	59	2.38	3.74	1.716	1.4	0.171
Carbon dioxide	68	3.55	3.07	1.130	1.29	0.155
Helium	68	0.326	4.09	12.42	1.66	0.753
Hydrogen	68	0.163	1.85	24.66	1.41	2.44
Methane	68	1.29	2.29	3.099	1.31	0.403
Nitrogen	68	2.26	3.68	1.775	1.40	0.177
Oxygen	68	2.58	4.25	1.554	1.40	0.157

TABLE C.6
Physical Properties of Certain Gases at Atmospheric Pressure (SI Units)

Gas	Temperature, T (°C)	Density, ρ (kg/m ³)	Dynamic Viscosity, $\mu \times 10^5$ (N-s/m ²)	Gas Constant, $R \times 10^{-2}$ (J/kg/K)	Specific Heat Ratio, k	Specific Heat Capacity, c_v (J/kg/K)
Air	15	1.23	1.79	2.869	1.4	717
Carbon dioxide	20	1.83	1.47	1.889	1.29	647
Helium	20	0.166	1.94	20.77	1.66	3125
Hydrogen	20	0.0838	0.884	41.24	1.41	10087
Methane	20	0.667	1.10	5.183	1.31	1685
Nitrogen	20	1.16	1.76	2.968	1.40	744
Oxygen	20	1.33	2.04	2.598	1.40	654

TABLE C.7
Physical Properties of Air at Standard Atmospheric Pressure

Ft-lb-s Units				SI Units			
Temperature, T (°F)	Density, $\rho \times 10^3$ (slug/ft ³)	Dynamic Viscosity, $\mu \times 10^7$ (lb-s/ft ²)	Speed of Sound, C (ft/s)	Temperature, T (°C)	Density, ρ (kg/m ³)	Dynamic Viscosity, $\mu \times 10^5$ (N-s/m ²)	Speed of Sound, C (m/s)
-40	2.94	3.29	1004	-20	1.40	1.63	319
-20	2.81	3.34	1028	0	1.29	1.71	331
0	2.68	3.38	1051	5	1.27	1.73	334
10	2.63	3.44	1062	10	1.25	1.76	337
20	2.57	3.50	1074	15	1.23	1.80	340
30	2.52	3.58	1085	20	1.20	1.82	343
40	2.47	3.60	1096	25	1.18	1.85	346
50	2.42	3.68	1106	30	1.17	1.86	349
60	2.37	3.75	1117	40	1.13	1.87	355
70	2.33	3.82	1128	50	1.11	1.95	360
80	2.29	3.86	1138	60	1.06	1.97	366
90	2.24	3.90	1149	70	1.03	2.03	371
100	2.20	3.94	1159	80	1.00	2.07	377
120	2.13	4.02	1180	90	0.972	2.14	382
140	2.06	4.13	1200	100	0.946	2.17	387

TABLE C.8
Physical Properties of Certain Solids (Pipe Materials) at 70°F

Pipe Material	Young's Modulus, E_p (psi)	Poisson's Ratio, μ_p	Specific Gravity, S	Thermal Expansion Coefficient, $\alpha \times 10^6$ (1/°F)
Steel	3.0×10^7	0.3	7.14	6.5
Ductile iron	2.4×10^7	0.28	7.08	6.2
Cast iron	1.34×10^7		7.14	5.8
Copper	1.6×10^7	0.3	8.94	9.8
Aluminum	1.05×10^7	0.33	2.71	1.3
Asbestos cement	3.4×10^6	0.3	—	4.5
Concrete	$5.7 \times 10^4 \times f_c^{1/2}$	0.3	2.1–2.7	7.0
PVC	4×10^5	0.38	1.4	30

Note: f_c is the 28-day compressive strength of the concrete.

Appendix A

Physical Properties of Fluids

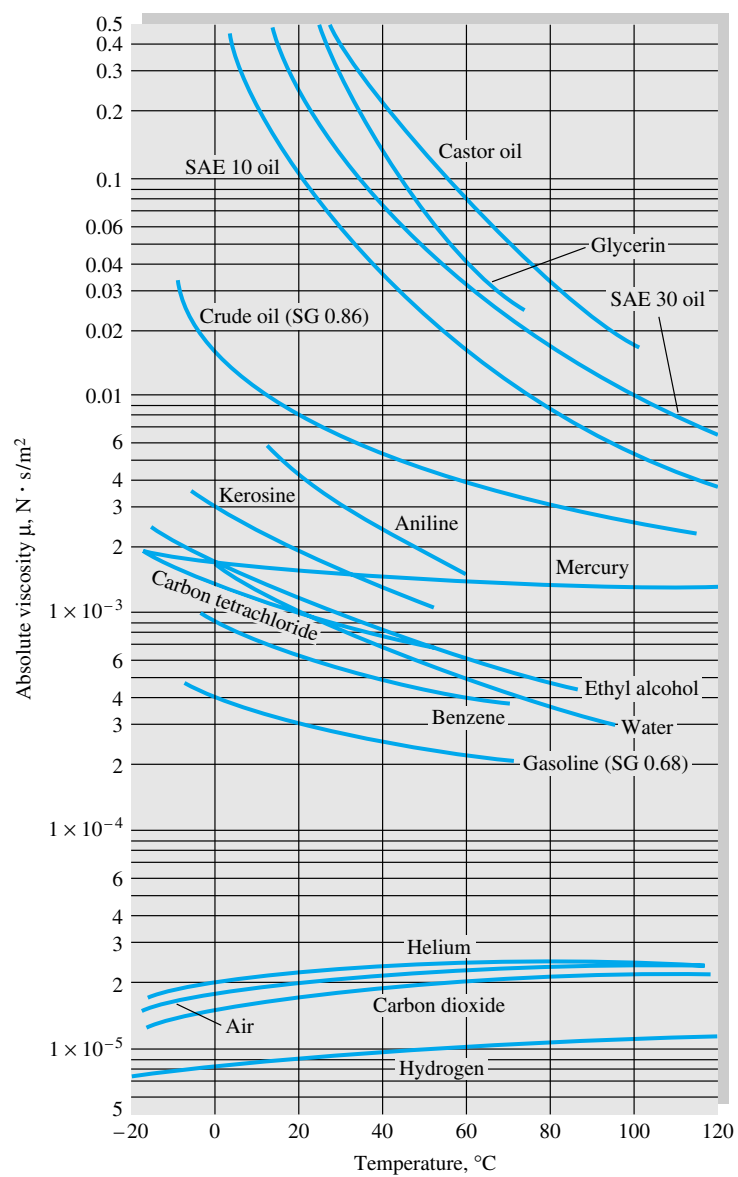

Fig. A.1 Absolute viscosity of common fluids at 1 atm.

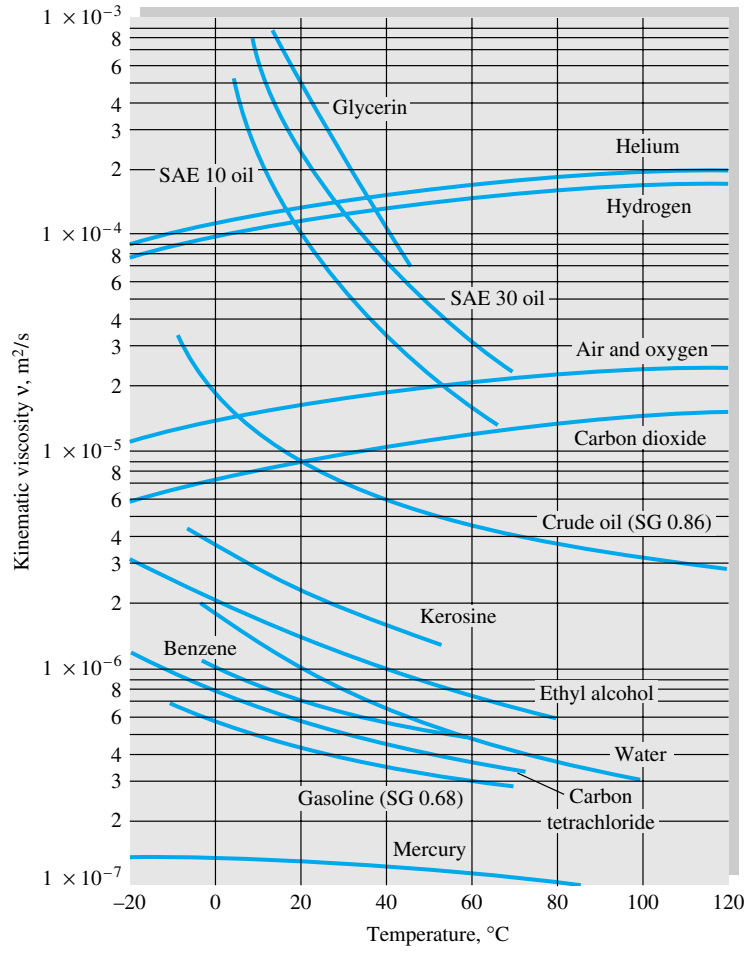

Fig. A.2 Kinematic viscosity of common fluids at 1 atm.

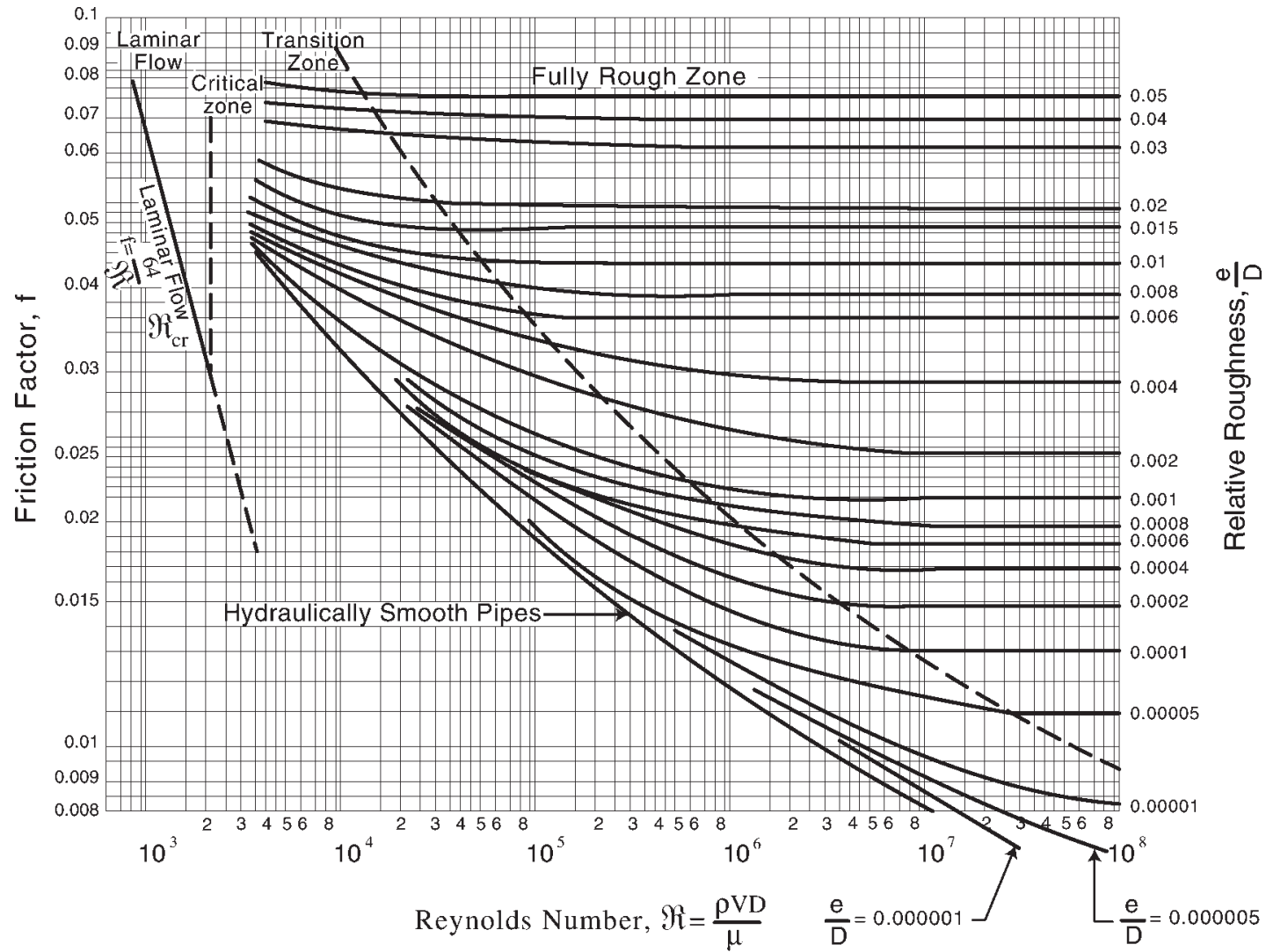
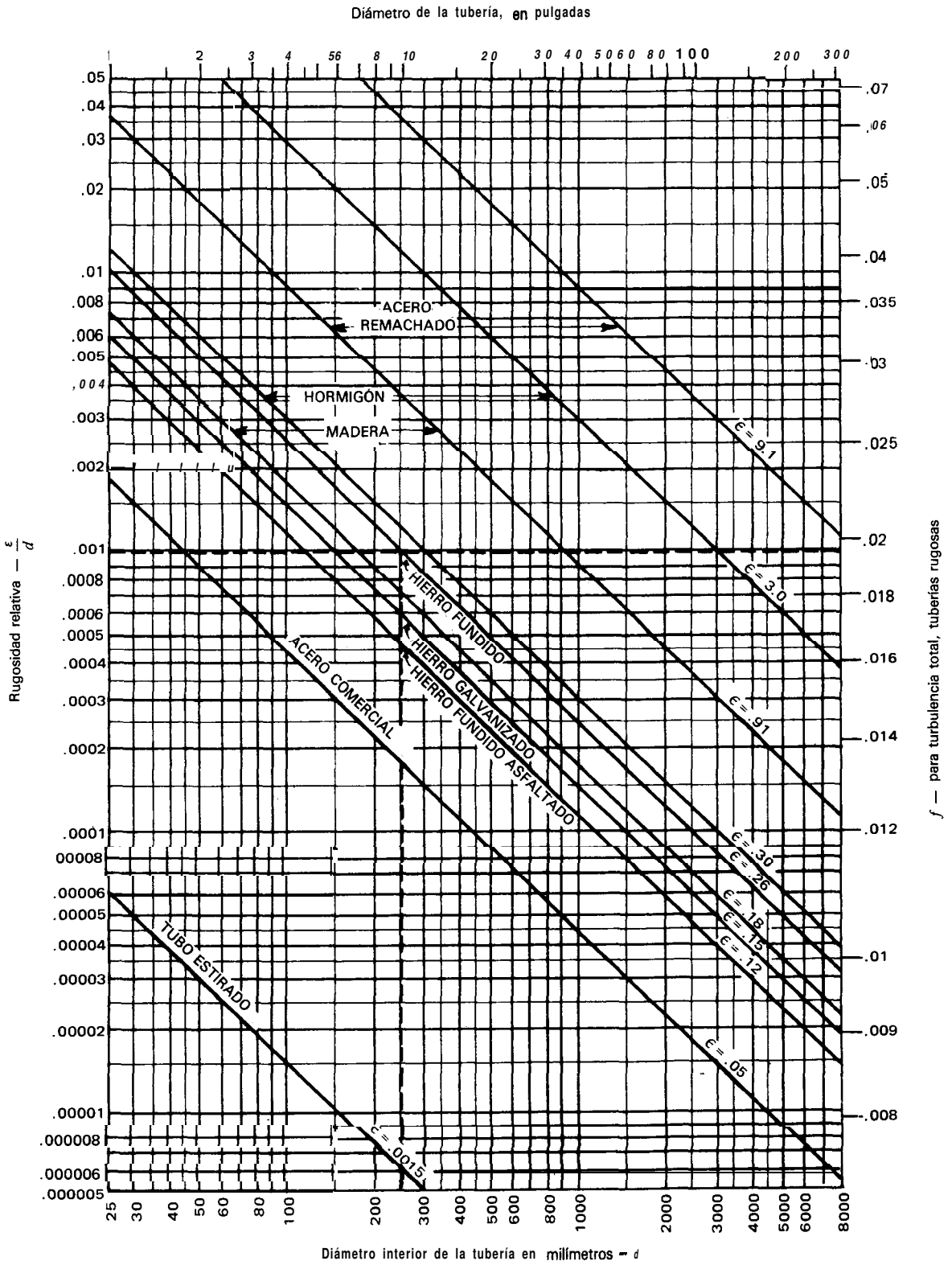

FIGURE 2.11 The Moody diagram.

A-21a. Rugosidad relativa de los materiales de las tuberías y factor de fricción para flujo en régimen de turbulencia total



(La rugosidad absoluta ϵ en milímetros)

Problema: Determinense las rugosidades absoluta y relativa y el factor de rozamiento para flujo en turbulencia total, en una tubería de hierro fundido de 250 mm de diámetro interior.
Solución: La rugosidad absoluta (ϵ) = 0.26... Rugosidad relativa (ϵ/d) = 0.001... Factor de fricción para flujo en régimen de turbulencia total (f) = 0.0196

Adaptación de datos extraídos de la referencia 18 de la Bibliografía.

A-21b. Rugosidad relativa de los materiales de las tuberías y factor de fricción para flujo en régimen de turbulencia total

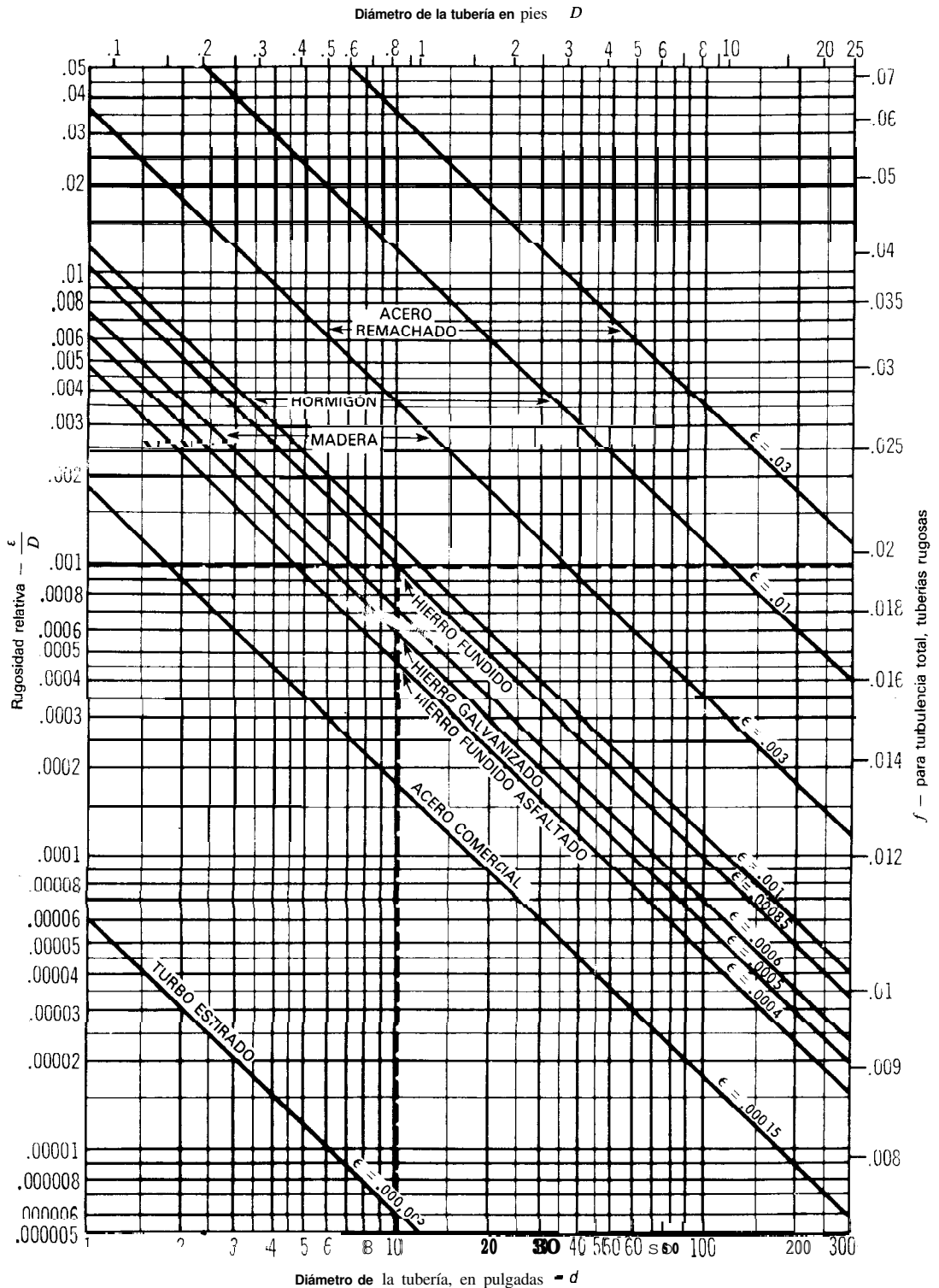

Adaptación de datos extraídos de la referencia 18 de la Bibliografía, con autorización.

Problema: Determinense las rugosidades absoluta y relativa y el factor de razonamiento para flujo en turbulencia total, en una tubería de hierro fundido de 10 pulg. de diámetro interior.
Solución: La rugosidad absoluta (ϵ) = 0.26... Rugosidad relativa (ϵ/D) = 0.001 . . . Factor de fricción para flujo en régimen de turbulencia total (f) = 0.0196

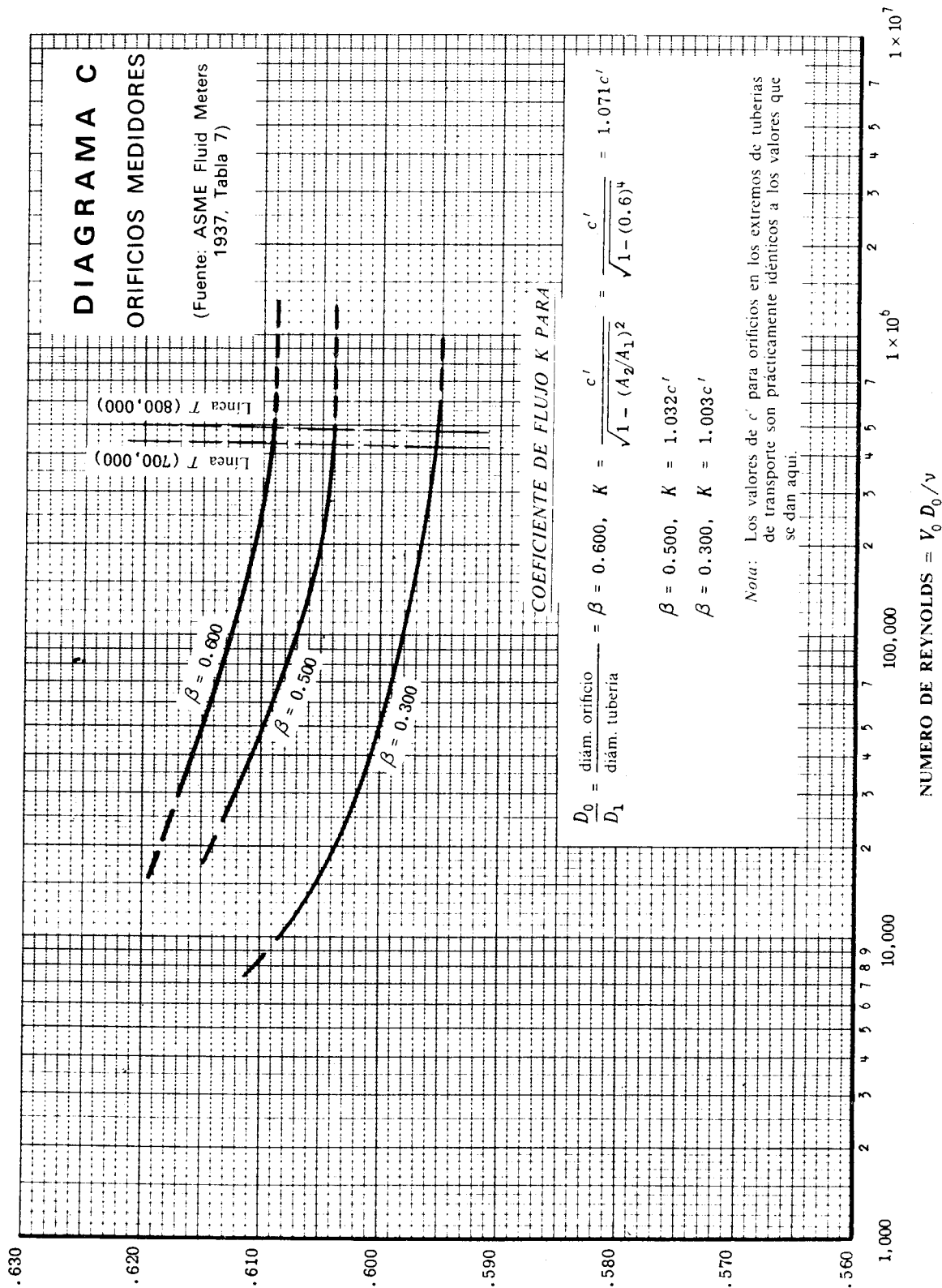

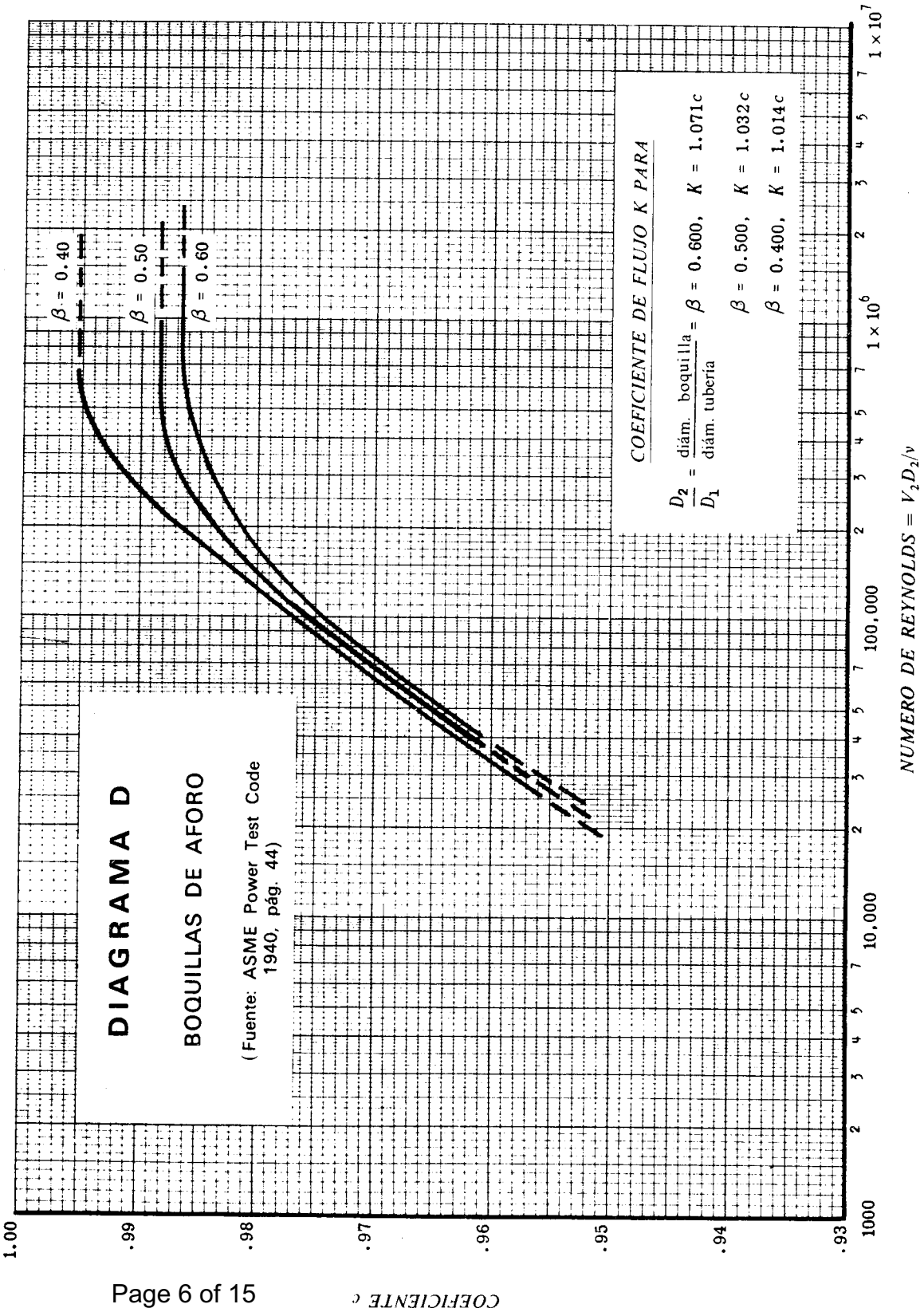



TABLA 3**COEFICIENTES DE FRICCIÓN f PARA AGUA SOLAMENTE**

(Intervalo de temperatura aproximado de 10° C a 21° C)

Para tuberías viejas – intervalo aproximado de ϵ : 0,12 cm a 0,60 cmPara tuberías usadas – intervalo aproximado de ϵ : 0,06 cm a 0,09 cmPara tuberías nuevas – intervalo aproximado de ϵ : 0,015 cm a 0,03 cm $(f = \text{valor tabulado} \times 10^{-4})$

Diámetro y tipo de tubería		VELOCIDAD (m/seg)										
		0,3	0,6	0,9	1,2	1,5	1,8	2,4	3,0	4,5	6,0	9,0
10 cm	Comercial vieja	435	415	410	405	400	395	395	390	385	375	370
	Comercial usada	355	320	310	300	290	285	280	270	260	250	250
	Tubería nueva	300	265	250	240	230	225	220	210	200	190	185
	Muy lisa	240	205	190	180	170	165	155	150	140	130	120
15 cm	Comercial vieja	425	410	405	400	395	395	390	385	380	375	365
	Comercial usada	335	310	300	285	280	275	265	260	250	240	235
	Tubería nueva	275	250	240	225	220	210	205	200	190	180	175
	Muy lisa	220	190	175	165	160	150	145	140	130	120	115
20 cm	Comercial vieja	420	405	400	395	390	385	380	375	370	365	360
	Comercial usada	320	300	285	280	270	265	260	250	240	235	225
	Tubería nueva	265	240	225	220	210	205	200	190	185	175	170
	Muy lisa	205	180	165	155	150	140	135	130	120	115	110
25 cm	Comercial vieja	415	405	400	395	390	385	380	375	370	365	360
	Comercial usada	315	295	280	270	265	260	255	245	240	230	225
	Tubería nueva	260	230	220	210	205	200	190	185	180	170	165
	Muy lisa	200	170	160	150	145	135	130	125	115	110	105
30 cm	Comercial vieja	415	400	395	395	390	385	380	375	365	360	355
	Comercial usada	310	285	275	265	260	255	250	240	235	225	220
	Tubería nueva	250	225	210	205	200	195	190	180	175	165	160
	Muy lisa	190	165	150	140	140	135	125	120	115	110	105
40 cm	Comercial vieja	405	395	390	385	380	375	370	365	360	350	350
	Comercial usada	300	280	265	260	255	250	240	235	225	215	210
	Tubería nueva	240	220	205	200	195	190	180	175	170	160	155
	Muy lisa	180	155	140	135	130	125	120	115	110	105	100
50 cm	Comercial vieja	400	395	390	385	380	375	370	365	360	350	350
	Comercial usada	290	275	265	255	250	245	235	230	220	215	205
	Tubería nueva	230	210	200	195	190	180	175	170	165	160	150
	Muy lisa	170	150	135	130	125	120	115	110	105	100	95
60 cm	Comercial vieja	400	395	385	380	375	370	365	360	355	350	345
	Comercial usada	285	265	255	250	245	240	230	225	220	210	200
	Tubería nueva	225	200	195	190	185	180	175	170	165	155	150
	Muy lisa	165	140	135	125	120	120	115	110	105	100	95
75 cm	Comercial vieja	400	385	380	375	370	365	360	355	350	350	345
	Comercial usada	280	255	250	245	240	230	225	220	210	205	200
	Tubería nueva	220	195	190	185	180	175	170	165	160	155	150
	Muy lisa	160	135	130	120	115	115	110	110	105	100	95
90 cm	Comercial vieja	395	385	375	370	365	360	355	355	350	345	340
	Comercial usada	275	255	245	240	235	230	225	220	210	200	195
	Tubería nueva	215	195	185	180	175	170	165	160	155	150	145
	Muy lisa	150	135	125	120	115	110	110	105	100	95	90
120 cm	Comercial vieja	395	385	370	365	360	355	350	350	345	340	335
	Comercial usada	265	250	240	230	225	220	215	210	200	195	190
	Tubería nueva	205	190	180	175	170	165	160	155	150	145	140
	Muy lisa	140	125	120	115	110	110	105	100	95	90	90

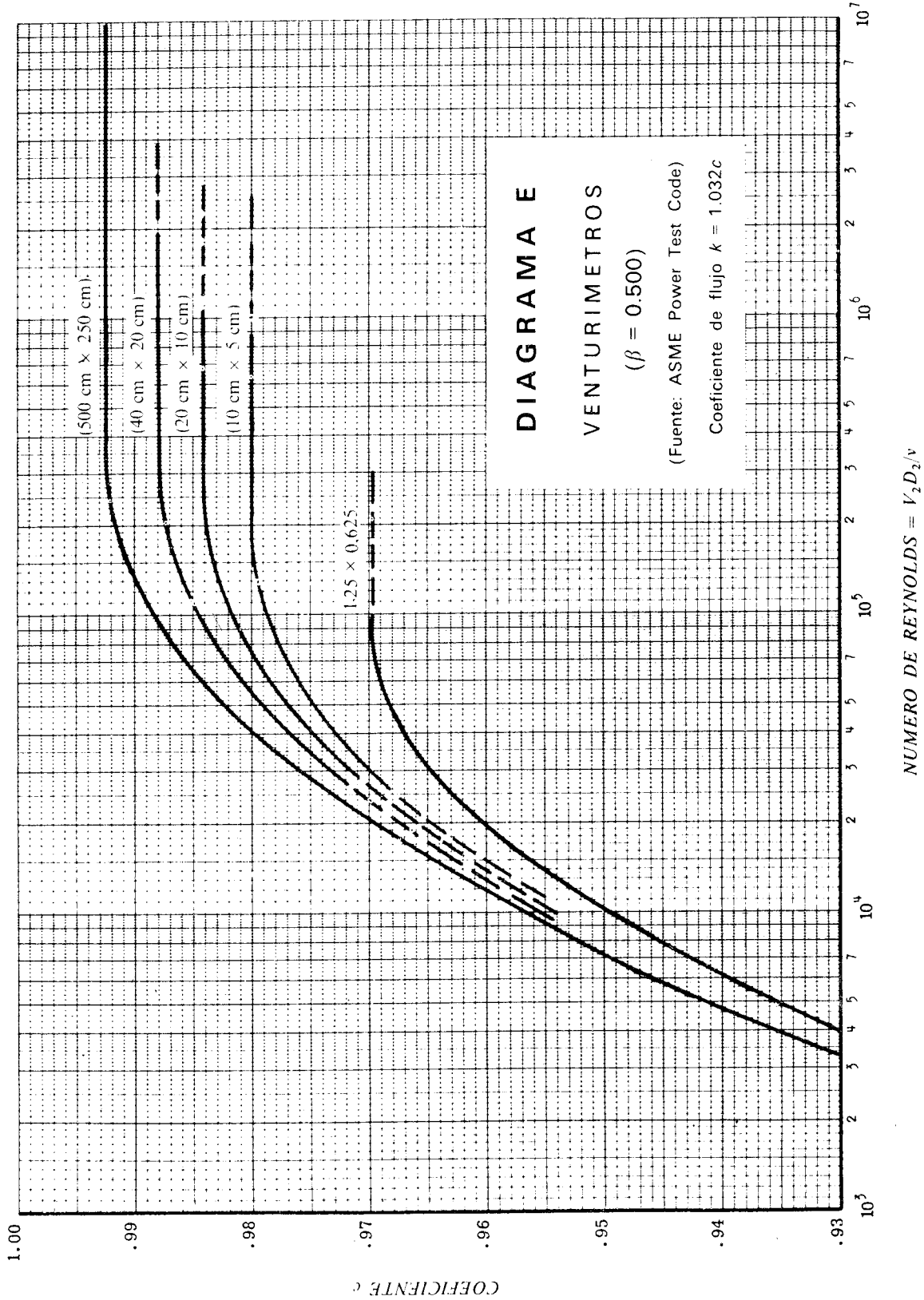
TABLA 4

PERDIDAS DE CARGA EN ACCESORIOS

(Subíndice 1 = aguas arriba y subíndice 2 = aguas abajo)

Accesorio	Pérdida de carga media
1. De depósito a tubería – conexión a ras de la pared (pérdida a la entrada)	$0,50 \frac{V_2^2}{2g}$
– tubería entrante	$1,00 \frac{V_2^2}{2g}$
– conexión abocinada	$0,05 \frac{V_2^2}{2g}$
2. De tubería a depósito (pérdida a la salida)	$1,00 \frac{V_1^2}{2g}$
3. Ensanchamiento brusco	$\frac{(V_1 - V_2)^2}{2g}$
4. Ensanchamiento gradual (véase Tabla 5)	$K \frac{(V_1 - V_2)^2}{2g}$
5. Venturímetros, boquillas y orificios	$\left(\frac{1}{c_v^2} - 1\right) \frac{V_2^2}{2g}$
6. Contracción brusca (véase Tabla 5)	$K_c \frac{V_2^2}{2g}$
7. Codos, accesorios, válvulas*	$K \frac{V^2}{2g}$
Algunos valores corrientes de K son:	
45°, codo	0,35 a 0,45
90°, codo	0,50 a 0,75
Tees	1,50 a 2,00
Válvulas de compuerta (abierta)	aprox. 0,25
Válvulas de control (abierta)	aprox. 3,0

* Véanse manuales de hidráulica para más detalles.

TABLA 5

VALORES DE K^*
Contracciones y ensanchamientos

Contracción brusca		Ensanchamiento gradual para un ángulo total del cono						
d_1/d_2	K_c	4°	10°	15°	20°	30°	50°	60°
1,2	0,08	0,02	0,04	0,09	0,16	0,25	0,35	0,37
1,4	0,17	0,03	0,06	0,12	0,23	0,36	0,50	0,53
1,6	0,26	0,03	0,07	0,14	0,26	0,42	0,57	0,61
1,8	0,34	0,04	0,07	0,15	0,28	0,44	0,61	0,65
2,0	0,37	0,04	0,07	0,16	0,29	0,46	0,63	0,68
2,5	0,41	0,04	0,08	0,16	0,30	0,48	0,65	0,70
3,0	0,43	0,04	0,08	0,16	0,31	0,48	0,66	0,71
4,0	0,45	0,04	0,08	0,16	0,31	0,49	0,67	0,72
5,0	0,46	0,04	0,08	0,16	0,31	0,50	0,67	0,72

* Valores tomados de King, *Handbook of Hydraulics*, McGraw-Hill Book Company.

TABLA 6

ALGUNOS VALORES DEL COEFICIENTE C_1 DE HAZEN-WILLIAMS

Tuberías rectas y muy lisas.....	140
Tuberías de fundición lisas y nuevas.....	130
Tuberías de fundición usadas y de acero roblonado nuevas.....	110
Tuberías de alcantarillado vitrificadas.....	110
Tuberías de fundición con algunos años de servicio.....	100
Tuberías de fundición en malas condiciones.....	80

TABLE 2.1
Typical Values of Head Loss Coefficient for Some Fittings

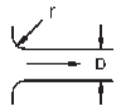
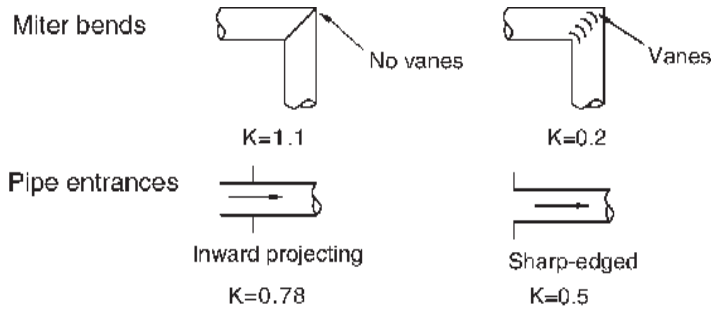

Round entrance:

r/D	0.02	0.04	0.06	0.10	>0.15
K	0.28	0.24	0.15	0.09	0.04

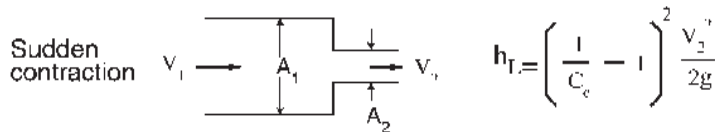
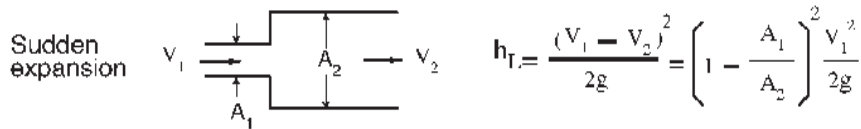
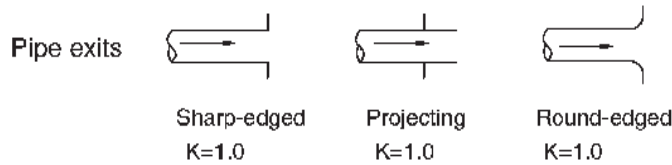

A_2/A_1	0.00	0.10	0.20	0.30	0.40	0.50	0.60	0.70	0.80	0.90	1.0
C_c	0.585	0.624	0.632	0.643	0.659	0.681	0.712	0.755	0.813	0.892	1.0

TABLE 2.2
Typical Values of Headloss Coefficient K for Selected Fittings

Fitting	K Value	Fitting	K Value
Check valves		Standard T	
Ball type	70	Side outlet	1.8
Disc type	10	Straight-through flow	0.4
Swing type	2		
Other valves		Elbows (90°)	
Foot valve	10	Regular	1.0
Globe valve	8	Long radius	0.4
Angle valve	3	Elbows (45°)	
Diaphragm valve	2	Regular	0.3
Gate valve	1.5	Long radius	0.2
Butterfly valve	0.2		
Full-bore ball valve	Negligible (<0.1)	Return bend	2.2

Note: All the K values given for valves are for fully open valves. For a given type of fitting, the K value may differ considerably for products of different manufacturers. It also depends on other factors such as whether the fittings are flanged, threaded, or welded to the pipe. Values given in this table should be considered approximate typical values. In practice, one should use test values supplied by manufacturers.

Referencias Bibliográficas:

Page 1, 14-15: Pipeline Engineering, Henry Liu

Page 2 - 13: Mecanica de Fluidos e Hidraulica, Ranald V. Giles

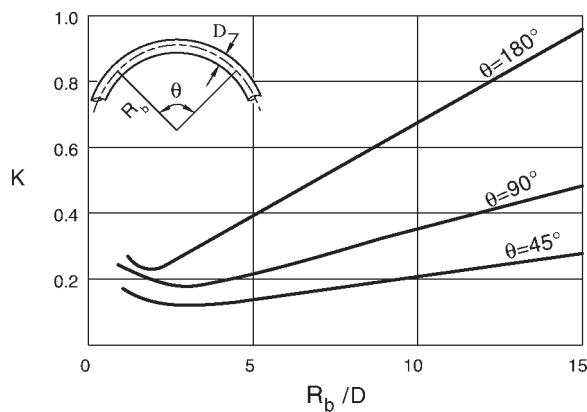
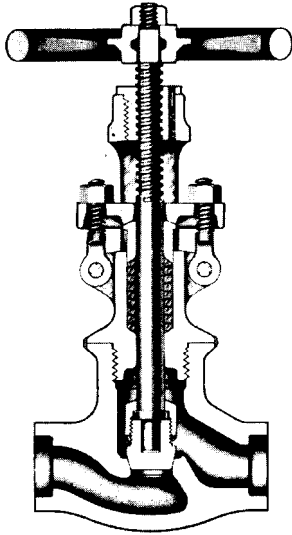
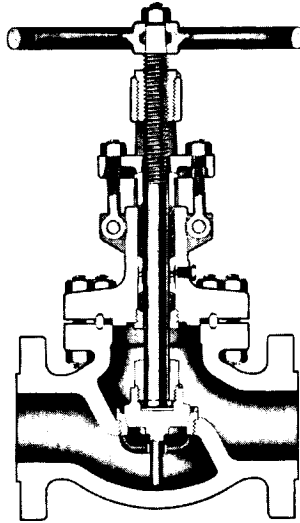

FIGURE 2.9 Headloss coefficient K for a smooth pipe bend ($\Re = 2 \times 10^5$).

A-15. Tipos de válvulas



Válvula de globo convencional



Válvula de globo convencional con obturador guiado

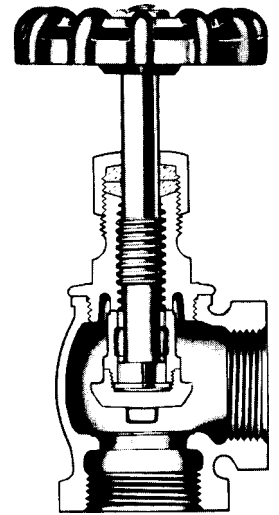

Válvula angular de globo convencional

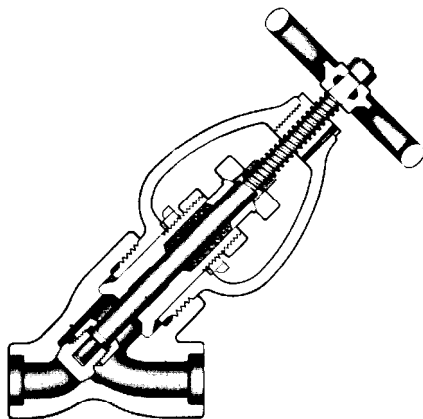

Válvula de globo, modelo en Y, con vástago a 45°

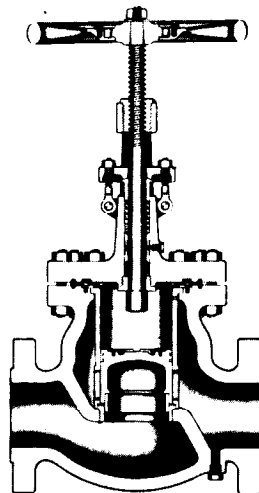

Válvula de retención y cierre, de paso recto

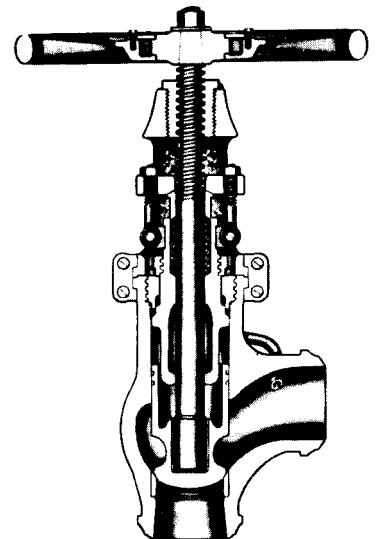

Válvula de retención y cierre, de paso angular

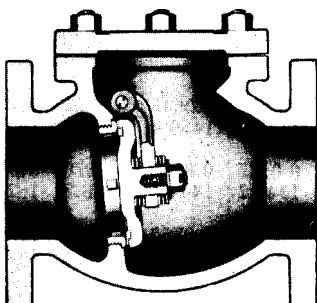

Válvula de retención convencional, de obturador oscilante

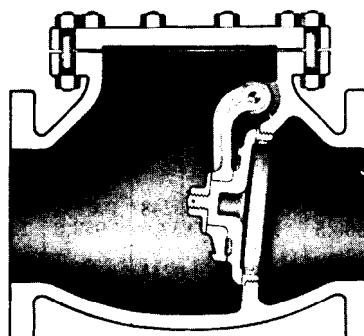

Válvula de retención de paso total con obturador oscilante

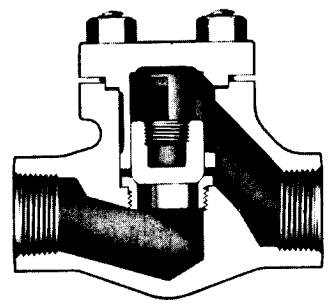

Válvula de retención de paso recto, con obturador ascendente

A-15. Tipos de válvulas (continuación)

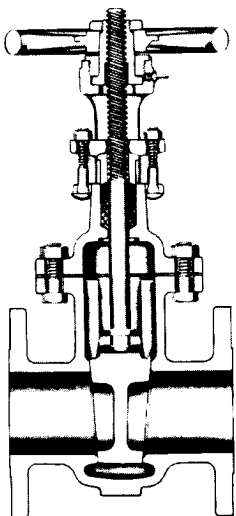

Válvula da compuerta da cuña (tapa atornillad.4

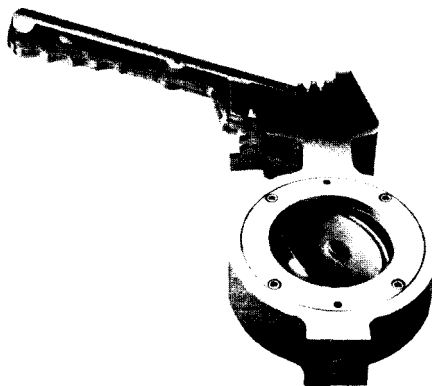

Válvula de mariposa da rendimiento alto

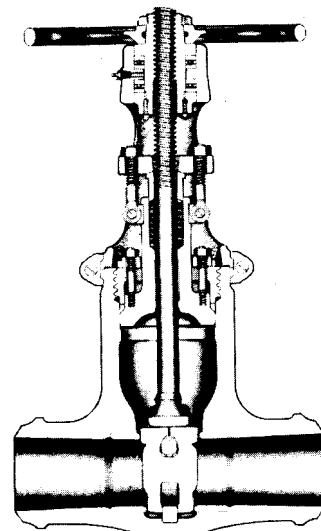

Válvula da compuerta de cuña flexible (tapa con sello a presión)

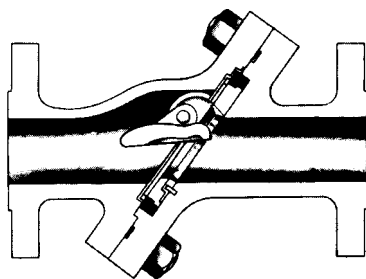

Válvula de retención de disco basculante



Válvula de mariposa sin bridas

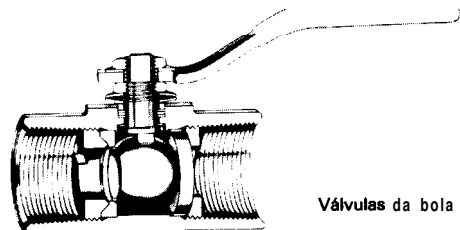

Válvulas da bola

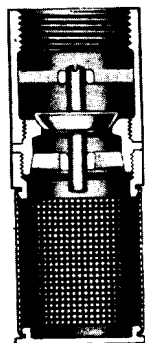
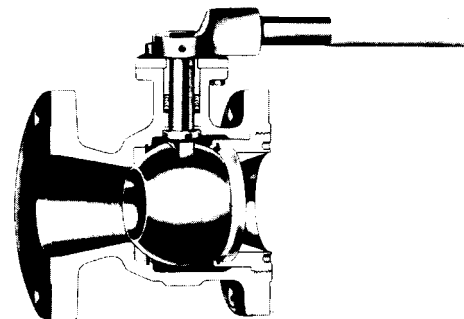

Válvulas de pie tipos oscilante y ascendente

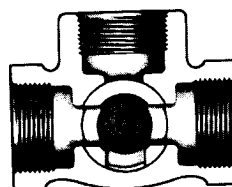
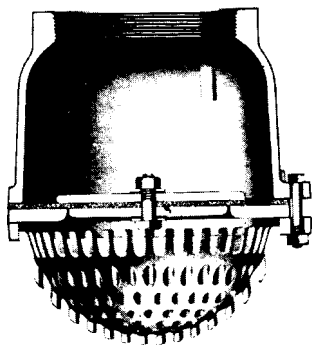

Llave de tres vías Vistas exterior y en sección

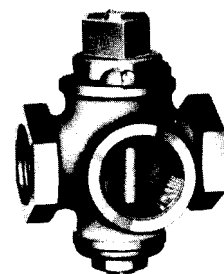

A-16. Coeficiente de flujo C para toberas para ambos sistemas

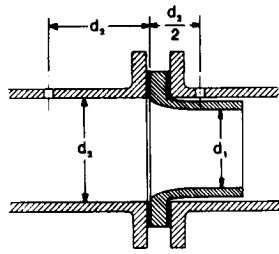

Sentido de flujo →

$$C = \frac{C_d}{\sqrt{1 - \beta^4}}$$

Ejemplo: El coeficiente de flujo C para una relación de diámetros β de 0.60 con un número de Reynolds de 20 000 (2×10^4) es igual a 1.03.

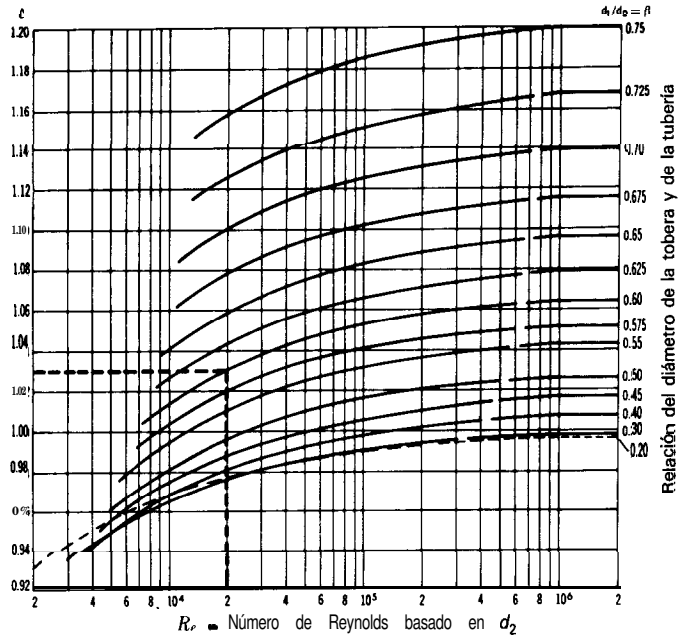

A-17. Coeficiente de flujo C para orificios de cantos vivos^{9,17}

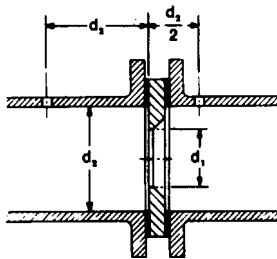

Sentido de flujo →

$$C = \frac{C_d}{\sqrt{1 - \beta^4}}$$

$$K_{\text{orificio}} \approx \frac{1 - \beta^2}{C^2 \beta^4}$$

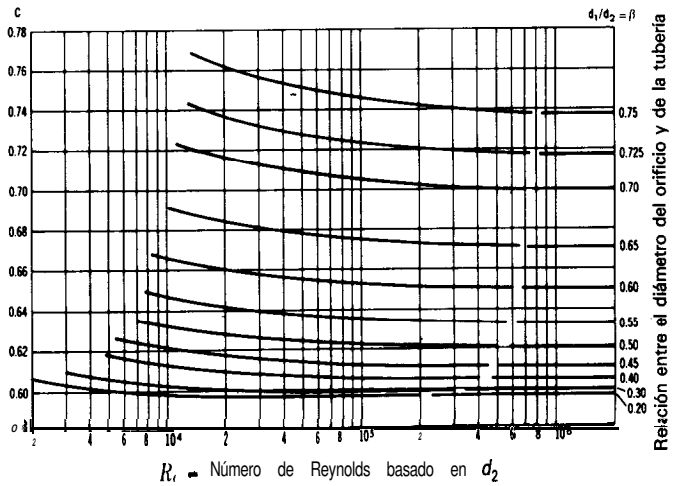
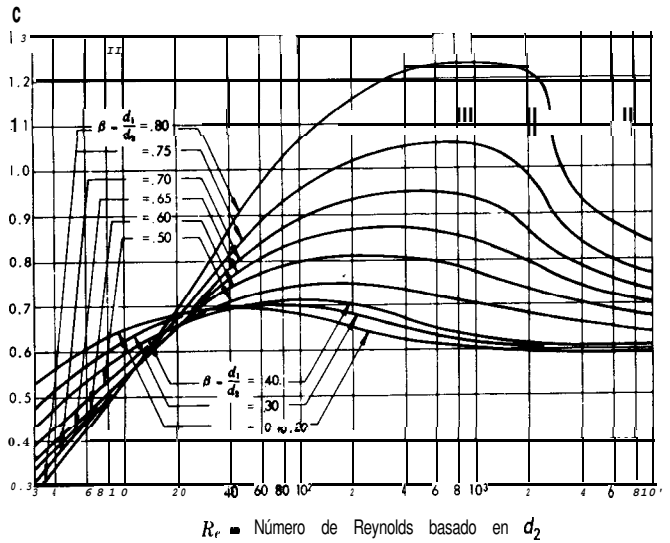

A-24. TABLA DEL FACTOR “K” (página 1 de 4)
Coefficientes de resistencia (K) válidos para válvulas y accesorios

(“K” está basado en el uso de las tuberías cuyos números de cédula se dan en la página 2-10)

**FACTORES DE FRICCIÓN PARA TUBERÍAS COMERCIALES, NUEVAS,
 DE ACERO, CON FLUJO EN LA ZONA DE TOTAL TURBULENCIA**

Diámetro Nominal	mm	15	20	25	32	40	50	65, 80	100	125	150	200,250	300400	450-600
	pulg	½	¾	1	1¼	1½	2	2½, 3	4	5	6	8: 10	12-16	18-24
Factor de fricción (f_T)		.027	.025	.023	.022	.021	.019	.018	.017	.016	.015	.014	.013	.012

**FÓRMULAS PARA EL CÁLCULO DEL FACTOR “K” PARA VÁLVULAS
 Y ACCESORIOS CON SECCIONES DE PASO REDUCIDO**

Fórmula 1

$$K_2 = \frac{0.8 \left(\text{sen } \frac{\theta}{2} \right) (1 - \beta^2)}{\beta^4} = \frac{K_1}{\beta^4}$$

Fórmula 2

$$K_2 = \frac{0.5 (1 - \beta^2) \sqrt{\text{sen } \frac{\theta}{2}}}{\beta^4} = \frac{K_1}{\beta^4}$$

Fórmula 3

$$K_2 = \frac{2.6 \left(\text{sen } \frac{\theta}{2} \right) (1 - \beta^2)^2}{\beta^4} = \frac{K_1}{\beta^4}$$

Fórmula 4

$$K_2 = \frac{(1 - \beta^2)^2}{\beta^4} = \frac{K_1}{\beta^4}$$

Fórmula 5

$$K_2 = \frac{K_1}{\beta^4} + \text{Fórmula 1} + \text{Fórmula 3}$$

$$K_2 = \frac{K_1 + \text{sen } \frac{\theta}{2} [0.8 (1 - \beta^2) + 2.6 (1 - \beta^2)^2]}{\beta^4}$$

Fórmula 6

$$K_2 = \frac{K_1}{\beta^4} + \text{Fórmula 2} + \text{Fórmula 4}$$

$$K_2 = \frac{K_1 + 0.5 \sqrt{\text{sen } \frac{\theta}{2}} (1 - \beta^2) + (1 - \beta^2)^2}{\beta^4}$$

Fórmula 7

$$K_2 = \frac{K_1}{\beta^4} + \beta (\text{Fórmula 2} + \text{Fórmula 4}), \text{ cuando } \theta = 180^\circ$$

$$K_2 = \frac{K_1 + \beta [0.5 (1 - \beta^2) + (1 - \beta^2)^2]}{\beta^4}$$

$$\beta = \frac{d_1}{d_2}$$

$$\beta^2 = \left(\frac{d_1}{d_2} \right)^2 = \frac{a_1}{a_2}$$

El subíndice 1 define dimensiones y coeficientes para el diámetro menor.
 El subíndice 2 se refiere al diámetro mayor.

*Úse el valor de K proporcionado por el proveedor, cuando se disponga de dicho valor

ESTRECHAMIENTO BRUSCO Y GRADUAL

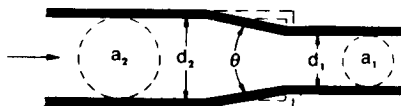

Si: $\theta < 4.5^\circ$ $K_2 = \text{Fórmula 1}$
 $45^\circ < \theta < 180^\circ$ $K_2 = \text{Fórmula 2}$

ENSANCHAMIENTO BRUSCO Y GRADUAL



Si: $\theta < 45^\circ$ $K_2 = \text{Fórmula 3}$
 $45^\circ < \theta < 180^\circ$ $K_2 = \text{Fórmula 4}$

A-24 TABLA DEL FACTOR "K" (página 2 de 4)
Coefficientes de resistencia (K) válidos para válvulas y accesorios

VÁLVULAS DE COMPUERTA

De cuña, de doble obturador o tipo macho (cónico)

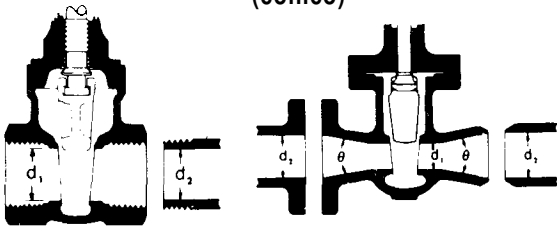

Si: $\beta = 1, \theta = 0 \dots \dots \dots K_1 = 8 f_T$
 $\beta < 1$ y $\theta < 45^\circ \dots \dots \dots K_2 = \text{Fórmula 5}$
 $\beta < 1$ y $45^\circ < \theta < 180^\circ \dots \dots K_2 = \text{Fórmula 6}$

VÁLVULAS DE RETENCIÓN DE DISCO OSCILANTE

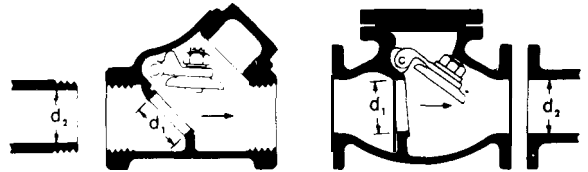

$K \approx 100 f_T$ $K = 50 f_T$

Velocidad mínima en la tubería para levantar totalmente el obturador

(m/seg) = $45 \sqrt{\bar{V}}$ = $75 \sqrt{\bar{V}}$
 (pie/seg) = $35 \sqrt{\bar{V}}$ = $60 \sqrt{\bar{V}}$
 U/L Registradas = $120 \sqrt{\bar{V}}$ = $100 \sqrt{\bar{V}}$

VÁLVULAS DE GLOBO Y ANGULARES

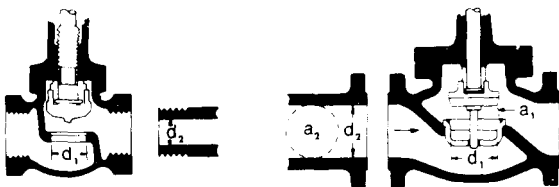

Si: $\beta = 1 \quad K_1 = 340 f_T$

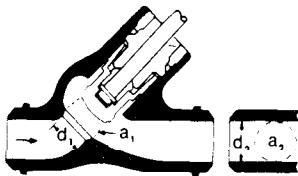

Si: $\beta = 1 \dots \dots K_1 = 55 f_T$

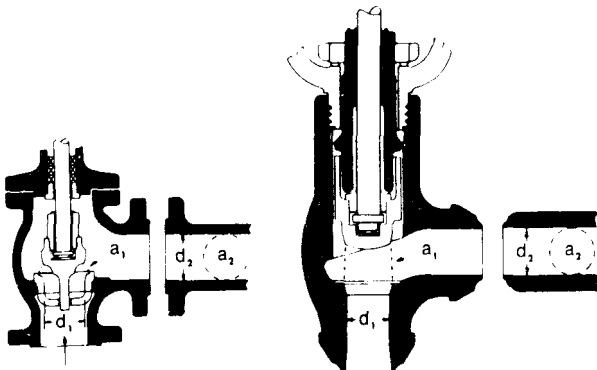

Si: $\beta = 1 \dots \dots K_1 = 150 f_T$ Si: $\beta = 1 \dots \dots K_1 = 55 f_T$

Todas las válvulas de globo y angulares con asiento reducido θ de mariposa

Si: $\beta < 1 \dots \dots K_2 = \text{Fórmula 7}$

VÁLVULAS DE RETENCIÓN DE OBTURADOR ASCENDENTE

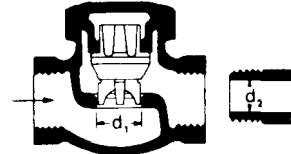

Si: $\beta = 1 \dots \dots K_1 = 600 f_T$
 $\beta < 1 \dots \dots K_2 = \text{Fórmula 7}$

Velocidad mínima en la tubería para levantar totalmente el obturador = $50 \beta^2 \sqrt{\bar{V}}$ m/seg $40 \beta^2 \sqrt{\bar{V}}$ pie/seg

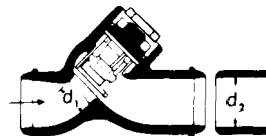

Si: $\beta = 1 \dots \dots K_1 = 55 f_T$
 $\beta < 1 \dots \dots K_2 = \text{Fórmula 7}$

Velocidad mínima en la tubería para levantar totalmente el obturador = $170 \beta^2 \sqrt{\bar{V}}$ m/seg $140 \beta^2 \sqrt{\bar{V}}$ pie/seg

VÁLVULAS DE RETENCIÓN DE DISCO BASCULANTE

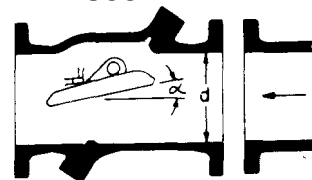

Pasos

	$\alpha = 5^\circ$	$\alpha = 15$
50 mm (2") a 200 mm (8")	$40 f_T$	$120 f_T$
250 mm (10") a 350 mm (14")	$30 f_T$	$90 f_T$
400 mm (16") a 1200 mm (48")	$20 f_T$	$60 f_T$
Velocidad mínima en la tubería para abrir totalmente el obturador = m/seg	$100 \sqrt{\bar{V}}$	$40 \sqrt{\bar{V}}$
pie/seg	$80 \sqrt{\bar{V}}$	$30 \sqrt{\bar{V}}$

A-24. TABLA DEL FACTOR "K" (página 3 de 4)
Coefficientes de resistencia (K) válidos para válvulas y accesorios

VÁLVULAS DE RETENCIÓN Y CIERRE
(Tipos recto y angular)

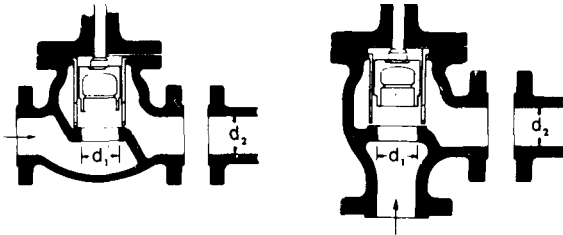

<p>Si: $\beta = 1 \dots K_1 = 400 f_T$ $\beta < 1 \dots K_2 = \text{Fórmula 7}$ Velocidad mínima en la tubería para levantar totalmente el obturador $m/\text{seg} = 70 \beta^2 \sqrt{V}$ $\text{pie}/\text{seg} = 55 \beta^2 \sqrt{V}$</p>	<p>Si: $\beta = 1 \dots K_1 = 200 f_T$ $\beta < 1 \dots K_2 = \text{Fórmula 7}$ Velocidad mínima en la tubería para levantar totalmente el obturador $= 95 \beta^2 \sqrt{V}$ $= 75 \beta^2 \sqrt{V}$</p>
---	--

VÁLVULAS DE PIE CON FILTRO

Obturador ascendente Obturador oscilante

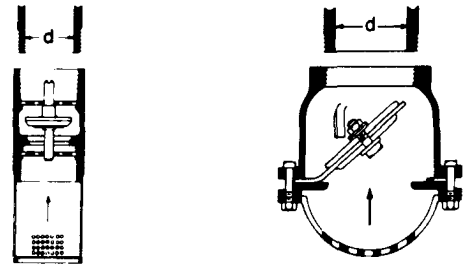

<p>$K = 420 f_T$ Velocidad mínima en la tubería para levantar totalmente el obturador $m/\text{seg} = 20 \sqrt{V}$ $\text{pie}/\text{seg} = 15 \sqrt{V}$</p>	<p>$K = 75 f_T$ Velocidad mínima en la tubería para levantar totalmente el obturador $= 45 \sqrt{V}$ $= 35 \sqrt{V}$</p>
--	--

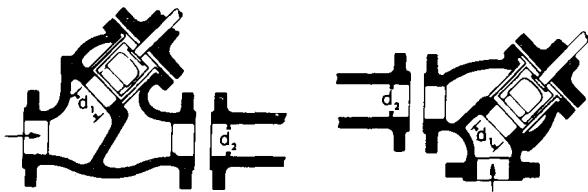

<p>Si: $\beta = 1 \dots K_1 = 300 f_T$ $\beta < 1 \dots K_2 = \text{Fórmula 7}$ velocidad mínima en la tubería para abrir totalmente el obturador $m/\text{seg} = 75 \beta^2 \sqrt{V}$</p>	<p>Si: $\beta = 1 \dots K_1 = 350 f_T$ $\beta < 1 \dots K_2 = \text{Fórmula 7}$ $\text{pie}/\text{seg} = 60 \beta^2 \sqrt{V}$</p>
--	--

VÁLVULAS DE GLOBO

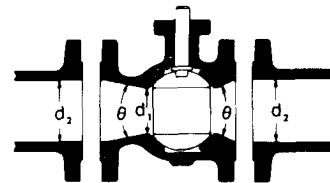

Si: $\beta = 1, \theta = 0 \dots K_1 = 3 f_T$
 $\beta < 1$ y $\theta < 45^\circ \dots K_2 = \text{Fórmula 5}$
 $\beta < 1$ y $45^\circ < \theta < 180^\circ \dots K_2 = \text{Fórmula 6}$



<p>$\beta = 1 \dots K_1 = 55 f_T$ $\beta < 1 \dots K_2 = \text{Fórmula 7}$ Velocidad mínima en la tubería para levantar totalmente el obturador $mg/\text{seg} = 170 \beta^2 \sqrt{V}$</p>	<p>$\beta = 1 \dots K_1 = 55 f_T$ $\beta < 1 \dots K_2 = \text{Fórmula 7}$ $(\text{pie}/\text{seg}) = 140 \beta^2 \sqrt{V}$</p>
---	---

VÁLVULAS DE MARIPOSA

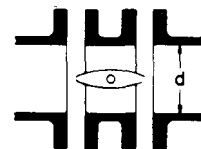

Diámetro 50 mm (2") a 200 mm (8") $K = 45 f_T$
 Diámetro 250 mm (10") a 350 mm (14") $K = 35 f_T$
 Diámetro 400 mm (16") a 600 mm (24") $K = 25 f_T$

A-24. TABLA DEL FACTOR "K" (página 4 de 4)
Coefficientes de resistencia (K) válidos para válvulas y accesorios

VÁLVULAS DE MACHO Y LLAVES

Paso directo

tres entradas

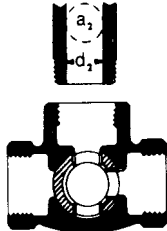
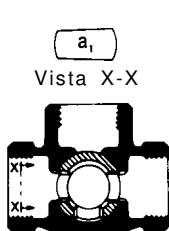
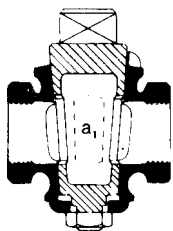

Si: $\beta = 1$,
 $K_1 = 18 f_T$

Si: $\beta = 1$,
 $K_1 = 30 f_T$

Si: $\beta = 1$,
 $K_1 = 90 f_T$

Si: $\beta < 1$ $K_2 = \text{Fórmula 6}$

CODOS ESTÁNDAR

90°

45°



$K = 30 f_T$

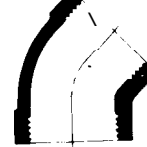

$K = 16 f_T$

CONEXIONES ESTÁNDAR EN "T"

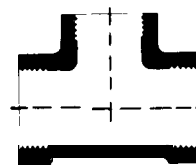

Flujo directo $K = 20 f_T$

Flujo desviado a 90° .. $K = 60 f_T$

CURVAS EN ESCUADRA O FALSA ESCUADRA

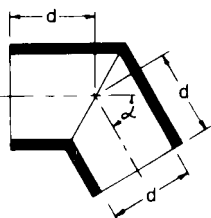

α	K
0°	$2 f_T$
15°	$4 f_T$
30°	$8 f_T$
45°	$15 f_T$
60°	$25 f_T$
75°	$40 f_T$
90°	$60 f_T$

CURVAS Y CODOS DE 90° CON BRIDAS O CON EXTREMOS PARA SOLDAR A TOPE

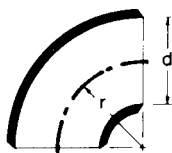

r/d	K	r/d	K
1	$20 f_T$	8	$24 f_T$
1.5	$14 f_T$	10	$30 f_T$
2	$12 f_T$	12	$34 f_T$
3	$12 f_T$	14	$38 f_T$
4	$14 f_T$	16	$42 f_T$
6	$17 f_T$	20	$50 f_T$

El coeficiente de resistencia K_B , para curvas que no sean de 90° puede determinarse con la fórmula:

$$K_B = (n - 1) \left(0.25 \pi f_T \frac{r}{d} + 0.5 K \right) + K$$

n = número de curvas de 90°

K = coeficiente de resistencia para una curva de 90° (según tabla)

ENTRADAS DE TUBERÍA

Con resalte hacia el interior

A tope

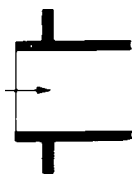

$K = 0.78$

r/d	K
0.00*	0.5
0.02	0.28
0.04	0.24
0.06	0.15
0.10	0.09
0.15 y más	0.04

*de cantos vivos

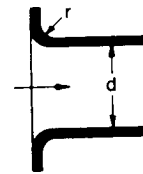

Véanse los valores de K en la tabla

CURVAS DE 180° DE RADIO CORTO

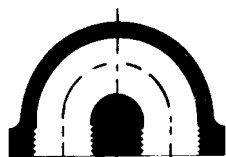

$K = 50 f_T$

SALIDAS DE TUBERÍA

Con resalte De cantos vivos Redondeada

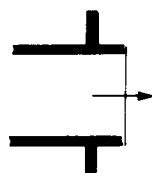

$K = 1.0$



$K = 1.0$

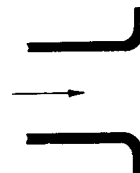

$K = 1.0$

A-25a. Longitudes equivalentes L y LID , nomograma del coeficiente de resistencia K

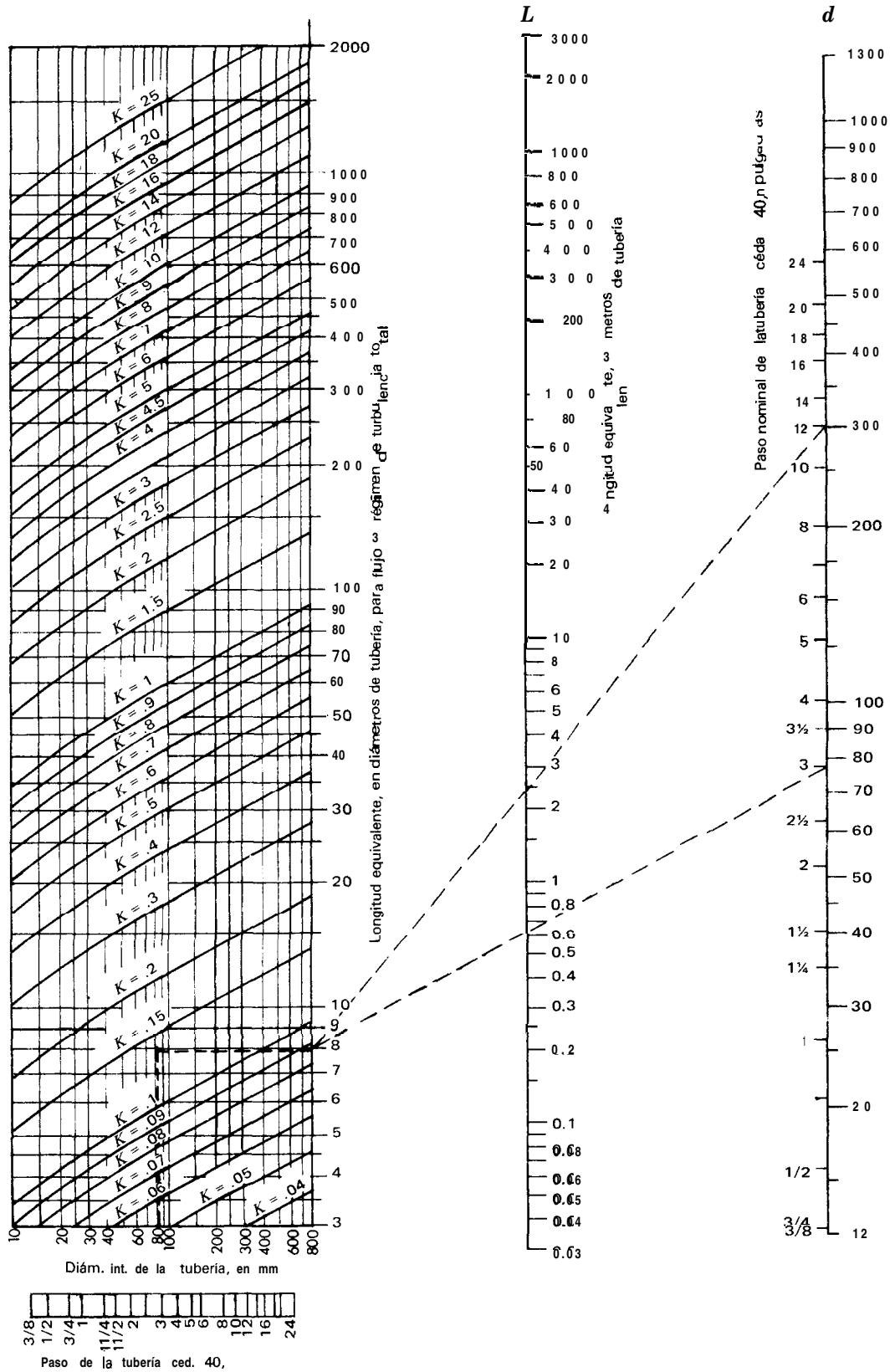

F1. Dimensiones de tubos de acero Calibre 40

Tamaño nominal de la tubería (pulgadas)	Diámetro exterior		Grosor de la pared		Diámetro interior			Área de flujo	
	(pulg)	(mm)	(pulg)	(mm)	(pulg)	(pie)	(mm)	(pie ²)	(m ²)
1/8	0.405	10.3	0.068	1.73	0.269	0.0224	6.8	0.000 394	3.660 × 10 ⁻⁵
1/4	0.540	13.7	0.088	2.24	0.364	0.0303	9.2	0.000 723	6.717 × 10 ⁻⁵
3/8	0.675	17.1	0.091	2.31	0.493	0.0411	12.5	0.001 33	1.236 × 10 ⁻⁴
1/2	0.840	21.3	0.109	2.77	0.622	0.0518	15.8	0.002 11	1.960 × 10 ⁻⁴
3/4	1.050	26.7	0.113	2.87	0.824	0.0687	20.9	0.003 70	3.437 × 10 ⁻⁴
1	1.315	33.4	0.133	3.38	1.049	0.0874	26.6	0.006 00	5.574 × 10 ⁻⁴
1 1/4	1.660	42.2	0.140	3.56	1.380	0.1150	35.1	0.010 39	9.653 × 10 ⁻⁴
1 1/2	1.900	48.3	0.145	3.68	1.610	0.1342	40.9	0.014 14	1.314 × 10 ⁻³
2	2.375	60.3	0.154	3.91	2.067	0.1723	52.5	0.023 33	2.168 × 10 ⁻³
2 1/2	2.875	73.0	0.203	5.16	2.469	0.2058	62.7	0.033 26	3.090 × 10 ⁻³
3	3.500	88.9	0.216	5.49	3.068	0.2557	77.9	0.051 32	4.768 × 10 ⁻³
3 1/2	4.000	101.6	0.226	5.74	3.548	0.2957	90.1	0.068 68	6.381 × 10 ⁻³
4	4.500	114.3	0.237	6.02	4.026	0.3355	102.3	0.088 40	8.213 × 10 ⁻³
5	5.563	141.3	0.258	6.55	5.047	0.4206	128.2	0.139 0	1.291 × 10 ⁻²
6	6.625	168.3	0.280	7.11	6.065	0.5054	154.1	0.200 6	1.864 × 10 ⁻²
8	8.625	219.1	0.322	8.18	7.981	0.6651	202.7	0.347 2	3.226 × 10 ⁻²
10	10.750	273.1	0.365	9.27	10.020	0.8350	254.5	0.547 9	5.090 × 10 ⁻²
12	12.750	323.9	0.406	10.31	11.938	0.9948	303.2	0.777 1	7.219 × 10 ⁻²
14	14.000	355.6	0.437	11.10	13.126	1.094	333.4	0.939 6	8.729 × 10 ⁻²
16	16.000	406.4	0.500	12.70	15.000	1.250	381.0	1.227	0.1140
18	18.000	457.2	0.562	14.27	16.876	1.406	428.7	1.553	0.1443
20	20.000	508.0	0.593	15.06	18.814	1.568	477.9	1.931	0.1794
24	24.000	609.6	0.687	17.45	22.626	1.886	574.7	2.792	0.2594





H. Dimensiones de tuberías de cobre tipo K

Tamaño nominal (pulg)	Diámetro exterior		Grosor de la pared		Diámetro interior			Área de flujo	
	(pulg)	(mm)	(pulg)	(mm)	(pulg)	(pie)	(mm)	(pie ²)	(m ²)
1/8	0.250	6.35	0.035	0.889	0.180	0.0150	4.572	1.767 × 10 ⁻⁴	1.642 × 10 ⁻⁵
1/4	0.375	9.53	0.049	1.245	0.277	0.0231	7.036	4.185 × 10 ⁻⁴	3.888 × 10 ⁻⁵
3/8	0.500	12.70	0.049	1.245	0.402	0.0335	10.21	8.814 × 10 ⁻⁴	8.189 × 10 ⁻⁵
1/2	0.625	15.88	0.049	1.245	0.527	0.0439	13.39	1.515 × 10 ⁻³	1.407 × 10 ⁻⁴
5/8	0.750	19.05	0.049	1.245	0.652	0.0543	16.56	2.319 × 10 ⁻³	2.154 × 10 ⁻⁴
3/4	0.875	22.23	0.065	1.651	0.745	0.0621	18.92	3.027 × 10 ⁻³	2.812 × 10 ⁻⁴
1	1.125	28.58	0.065	1.651	0.995	0.0829	25.27	5.400 × 10 ⁻³	5.017 × 10 ⁻⁴
1 1/4	1.375	34.93	0.065	1.651	1.245	0.1037	31.62	8.454 × 10 ⁻³	7.854 × 10 ⁻⁴
1 1/2	1.625	41.28	0.072	1.829	1.481	0.1234	37.62	1.196 × 10 ⁻²	1.111 × 10 ⁻³
2	2.125	53.98	0.083	2.108	1.959	0.1632	49.76	2.093 × 10 ⁻²	1.945 × 10 ⁻³
2 1/2	2.625	66.68	0.095	2.413	2.435	0.2029	61.85	3.234 × 10 ⁻²	3.004 × 10 ⁻³
3	3.125	79.38	0.109	2.769	2.907	0.2423	73.84	4.609 × 10 ⁻²	4.282 × 10 ⁻³
3 1/2	3.625	92.08	0.120	3.048	3.385	0.2821	85.98	6.249 × 10 ⁻²	5.806 × 10 ⁻³
4	4.125	104.8	0.134	3.404	3.857	0.3214	97.97	8.114 × 10 ⁻²	7.538 × 10 ⁻³
5	5.125	130.2	0.160	4.064	4.805	0.4004	122.0	1.259 × 10 ⁻¹	1.170 × 10 ⁻²
6	6.125	155.6	0.192	4.877	5.741	0.4784	145.8	1.798 × 10 ⁻¹	1.670 × 10 ⁻²
8	8.125	206.4	0.271	6.883	7.583	0.6319	192.6	3.136 × 10 ⁻¹	2.914 × 10 ⁻²
10	10.125	257.2	0.338	8.585	9.449	0.7874	240.0	4.870 × 10 ⁻¹	4.524 × 10 ⁻²
12	12.125	308.0	0.405	10.287	11.315	0.9429	287.4	6.983 × 10 ⁻¹	6.487 × 10 ⁻²

I. Dimensiones de tubos de hierro dúctil

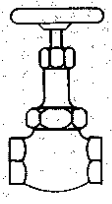
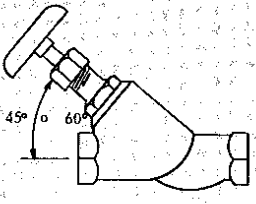
Tamaño nominal (pulg)	Diámetro exterior		Grosor de la pared		Diámetro interior			Área de flujo	
	(pulg)	(mm)	(pulg)	(mm)	(pulg)	(pie)	(mm)	(pie ²)	(m ²)
3	3.96	100.6	0.320	8.13	3.32	0.277	84.3	0.0601	5.585 × 10 ⁻³
4	4.80	121.9	0.350	8.89	4.10	0.342	104.1	0.0917	8.518 × 10 ⁻³
6	6.90	175.3	0.380	9.65	6.14	0.512	156.0	0.2056	1.910 × 10 ⁻²
8	9.05	229.9	0.410	10.41	8.23	0.686	209.0	0.3694	3.432 × 10 ⁻²
10	11.10	281.9	0.440	11.18	10.22	0.852	259.6	0.5697	5.292 × 10 ⁻²
12	13.20	335.3	0.480	12.19	12.24	1.020	310.9	0.8171	7.591 × 10 ⁻²
14	15.65	397.5	0.510	12.95	14.63	1.219	371.6	1.167	0.1085
16	17.80	452.1	0.540	13.72	16.72	1.393	424.7	1.525	0.1417
18	19.92	506.0	0.580	14.73	18.76	1.563	476.5	1.920	0.1783
20	22.06	560.3	0.620	15.75	20.82	1.735	528.8	2.364	0.2196
24	26.32	668.5	0.730	18.54	24.86	2.072	631.4	3.371	0.3132

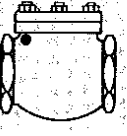
TABLA 10. PÉRDIDAS DE CARGA EN LAS VÁLVULAS EXPRESADAS EN LONGITUD EQUIVALENTE DE TUBO (m) *
Uniones con extremos roscados, soldados, embreados o cónicos

DIÁMETRO EXTERIOR		ESFÉRICAS **	60°-Y		45°-Y		VÁLVULAS DE COMPUERTA *****	VÁLVULAS DE RETENCIÓN	
ACERO	COBRE		ANGULARES **		ANGULARES **			OSCILANTE ***	DE CIERRE VERTICAL (horizontal de retención)
									
17,2	1/2	5,1	2,4	1,8	1,8	0,18	1,5	RECTAS COMO GRIFOS DE VÁLVULA ESFÉRICA *****	
21,3	5/8	5,4	2,7	2,1	2,1	0,21	1,8		
26,9	7/8	6,6	3,3	2,7	2,7	0,27	2,4		
33,7	1 1/8	8,7	4,6	3,6	3,6	0,30	3,6		
42,4	1 3/8	11,4	6,1	4,6	4,6	0,46	4,2		
48,3	1 5/8	12,6	7,3	5,4	5,4	0,54	4,8		
60,3	2 1/8	16,5	9,1	7,3	7,3	0,70	6,1		
73	2 5/8	20,7	10,7	8,7	8,7	0,85	7,6		
88,9	3 1/8	25,2	13,1	10,7	10,7	0,98	9,1		
101,6	3 5/8	30,5	15,2	12,5	12,5	1,2	10,7		
114,3	4 1/8	36,8	17,7	14,6	14,6	1,4	12,2	ANGULARES COMO GRIFOS DE VÁLVULA ANGULARES	
141,3	5 1/8	42,6	21,6	17,7	17,7	1,8	15,3		
168,3	6 1/8	52,0	26,8	21,4	21,4	2,1	18,3		
219,1	8 1/8	67,1	35,1	26,0	26,0	2,7	24,4		
273	-	85,4	44,2	32,0	32,0	3,6	30,5		
323,9	-	97,5	50,4	40,0	40,0	3,9	36,6		
355,6	-	109,9	56,5	47,4	47,4	4,6	41,2		
406,4	-	125,0	64,0	55,0	55,0	5,1	45,8		
457,2	-	140,1	73,1	61,1	61,1	5,7	50,4		
508	-	158,5	84,0	71,6	71,6	6,6	61,0		
609,6	-	186	97,5	81,0	81,0	7,5	73,2		

* Valores correspondientes a la posición de apertura total.
 ** Estos valores no se aplican a las válvulas de aguja.
 *** Estos valores se aplican también a las válvulas de retención rectas con obturador esférico.
 **** Para válvulas de retención inclinadas, cuyo diámetro de orificio es igual al del tubo, tomar los valores correspondientes a las válvulas con tija inclinada 60°
 ***** Las válvulas de macho presentan la misma pérdida de carga, en la posición de apertura total, que las de paso directo.





TABLA 11. PÉRDIDAS DE CARGA DE LOS CODOS Y «T» EXPRESADOS EN LONGITUD EQUIVALENTE DE TUBO (m)
Uniones con extremos roscados, soldados, embreados o cónicos

DIÁMETRO EXTERIOR		CODOS						T				
Acero	Cobre	Radio pequeño 90° *	Radio grande 90° **	Macho Hembra 90° *	Radio pequeño 45° *	Macho Hembra 45° *	Radio pequeño 180° *	Cambio de dirección	PASO DIRECTO			
									Sin reducción	Reducción 1/4	Reducción 1/2	
17,2	1/2	0,42	0,27	0,70	0,21	0,33	0,70	0,82	0,27	0,36	0,42	
21,3	5/8	0,48	0,30	0,76	0,24	0,40	0,76	0,91	0,30	0,43	0,48	
26,9	7/8	0,61	0,42	0,98	0,27	0,49	0,98	1,2	0,42	0,58	0,61	
33,7	1 1/8	0,79	0,51	1,2	0,39	0,64	1,2	1,5	0,51	0,70	0,79	
42,4	1 3/8	1,0	0,70	1,7	0,51	0,91	1,7	2,1	0,70	0,95	1,0	
48,3	1 5/8	1,2	0,80	1,9	0,64	1,0	1,9	2,4	0,80	1,1	1,2	
60,3	2 1/8	1,5	1,0	2,5	0,79	1,4	2,5	3,0	1,0	1,4	1,5	
73	2 5/8	1,8	1,2	3,0	0,98	1,6	3,0	3,6	1,2	1,7	1,8	
88,9	3 1/8	2,3	1,5	3,6	1,2	2,0	3,6	4,6	1,5	2,1	2,3	
101,6	3 5/8	2,7	1,8	4,6	1,4	2,2	4,6	5,4	1,8	2,4	2,7	
114,3	4 1/8	3,0	2,0	5,1	1,6	2,6	5,1	6,4	2,0	2,7	3,0	
141,3	5 1/8	4,0	2,5	6,4	2,0	3,3	6,4	7,6	2,5	3,6	4,0	
168,3	6 1/8	4,9	3,0	7,6	2,4	4,0	7,6	9,1	3,0	4,2	4,8	
219,1	8 1/8	6,1	4,0	-	3,0	-	10,4	10,7	4,0	5,4	6,1	
273	-	7,7	4,9	-	4,0	-	12,8	15,2	4,9	7,0	7,6	
323,9	-	9,1	5,8	-	4,9	-	15,3	18,3	5,8	7,9	9,1	
355,6	-	10,4	7,0	-	5,4	-	16,8	20,7	7,0	9,1	10,4	
406,4	-	11,6	7,9	-	6,1	-	18,9	23,8	7,9	10,7	11,6	
457,2	-	12,8	8,8	-	7,0	-	21,4	26,0	8,8	12,2	12,8	
508	-	15,3	10,4	-	7,9	-	24,7	30,5	10,4	13,4	15,2	
609,6	-	18,3	12,2	-	9,1	-	28,8	35,0	12,2	15,2	18,3	

DIÁMETRO EXTERIOR		CODOS ANGULARES			
Acero	Cobre	90°	60°	45°	30°
17,2	1/2	0,82	0,33	0,18	0,09
21,3	5/8	0,91	0,40	0,21	0,12
26,9	7/8	1,2	0,49	0,27	0,15
33,7	1 1/8	1,5	0,64	0,30	0,21
42,4	1 3/8	2,1	0,91	0,46	0,27
48,3	1 5/8	2,4	1,0	0,54	0,33
60,3	2 1/8	3,0	1,4	0,70	0,39
73	2 5/8	3,6	1,6	0,85	0,51
88,9	3 1/8	4,6	2,0	0,98	0,61
101,6	3 5/8	5,4	2,2	1,2	0,73
114,3	4 1/8	6,4	2,6	1,4	0,82
141,3	5 1/8	7,6	3,3	1,8	0,98
168,3	6 1/8	9,1	4,0	2,1	1,2
219,1	8 1/8	10,7	5,2	2,7	1,5
273	-	15,2	6,4	3,6	2,2
323,9	-	18,3	7,6	3,9	2,4
355,6	-	20,7	8,9	4,6	2,7
406,4	-	23,8	9,5	5,1	3,0
457,2	-	26,0	11,3	5,7	3,3
508	-	30,5	12,5	6,6	3,9
609,6	-	35,0	14,9	7,5	4,8

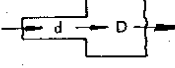
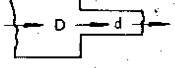
- * R/D sensiblemente igual a 1.
- ** R/D sensiblemente igual a 1,5.

TABLA 12. PÉRDIDAS DE CARGA EN LOS CAMBIOS DE SECCIÓN EXPRESADOS EN LONGITUD EQUIVALENTE DE TUBO (m)

DIÁMETRO EXTERIOR		Ensanchamiento brusco d/D *			Contracción brusca d/D *			Aristas vivas *		Orificio entrante *	
		1/4	1/2	3/4	1/4	1/2	3/4	Entrada	Salida	Entrada	Salida
Acero	Cobre										
17,2	1/2	0,42	0,24	0,09	0,21	0,15	0,09	0,46	0,24	0,45	0,34
21,3	5/8	0,54	0,33	0,12	0,27	0,21	0,12	0,54	0,30	0,54	0,46
26,9	7/8	0,79	0,46	0,15	0,36	0,30	0,15	0,85	0,42	0,85	0,67
33,7	1 1/8	0,98	0,61	0,21	0,49	0,36	0,21	1,1	0,54	1,1	0,82
42,4	1 3/8	1,4	0,91	0,30	0,70	0,54	0,30	1,6	0,79	1,6	1,3
48,3	1 5/8	1,8	1,1	0,36	0,88	0,66	0,36	2,0	1,0	2,0	1,5
60,3	2 1/8	2,4	1,5	0,49	1,2	0,91	0,49	2,7	1,3	2,7	2,0
73	2 5/8	3,0	1,9	0,61	1,5	1,2	0,61	3,6	1,7	3,6	2,6
88,9	3 1/8	4,0	2,4	0,79	2,0	1,5	0,79	4,3	2,2	4,2	3,3
101,6	3 5/8	4,6	2,8	0,91	2,3	1,8	0,91	5,2	2,6	5,2	3,9
114,3	4 1/8	5,2	3,3	1,2	2,7	2,1	1,2	6,1	3,0	6,1	4,9
141,3	5 1/8	7,3	4,6	1,5	3,6	2,7	1,5	8,2	4,2	8,2	6,1
168,3	6 1/8	8,8	6,7	1,8	4,6	3,3	1,8	10,1	5,8	10,1	7,6
219,1	8 1/8	-	7,6	2,6	-	4,6	2,6	14,3	7,3	14,3	10,7
273	-	-	9,8	3,3	-	6,1	3,3	18,3	8,8	18,3	14,0
323,9	-	-	12,5	3,9	-	7,6	3,9	22,2	11,3	22,2	17,4
355,6	-	-	-	4,9	-	-	4,9	26,2	13,7	26,2	20,0
406,4	-	-	-	5,5	-	-	5,5	29,3	15,3	29,2	23,4
457,2	-	-	-	6,1	-	-	6,1	35,0	17,7	35,0	27,4
508	-	-	-	-	-	-	-	43,4	21,4	43,2	32,0
609,6	-	-	-	-	-	-	-	49,8	25,3	49,6	39,6

* Entrar en la tabla con el diámetro pequeño.

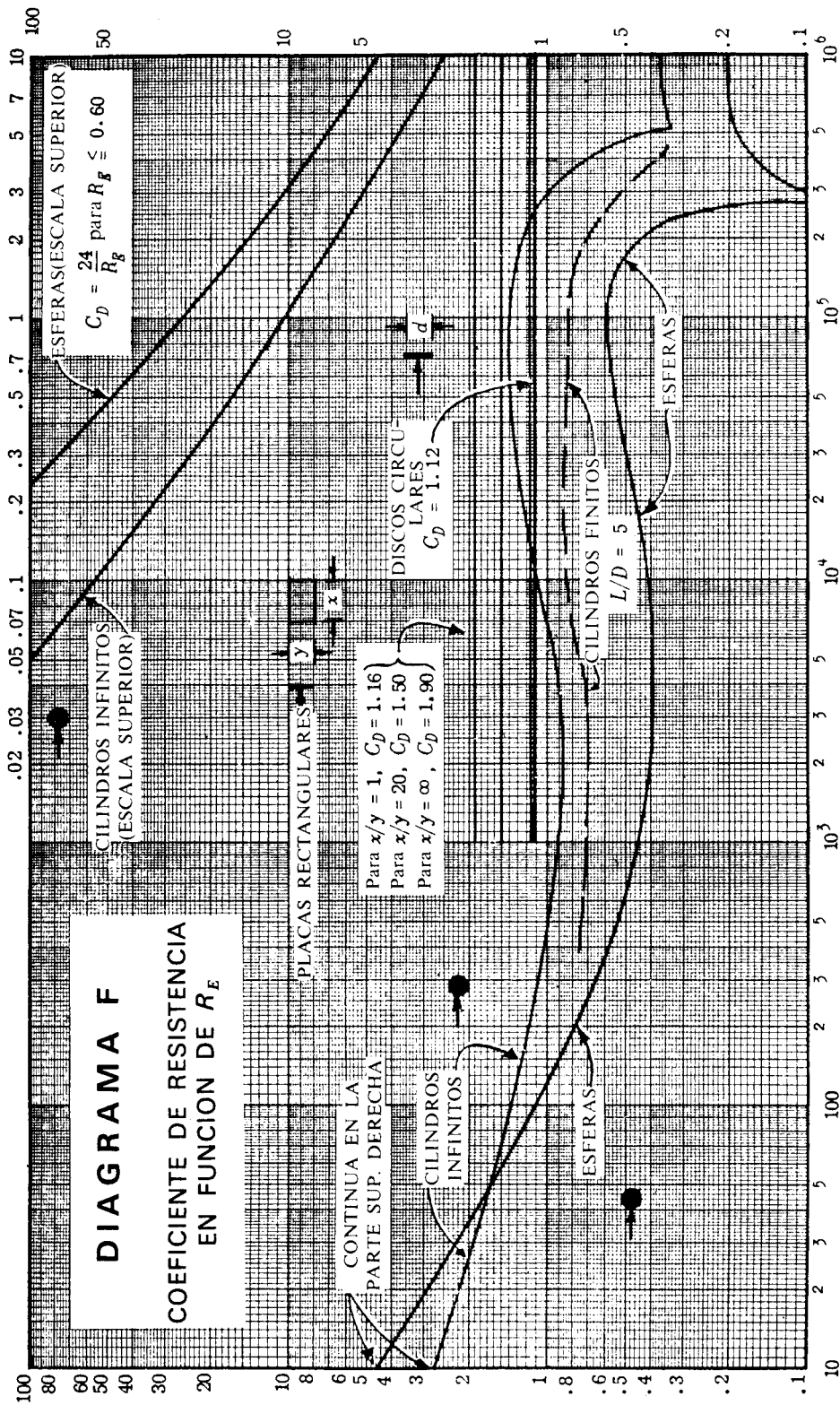

NUMERO DE REYNOLDS (VD/v)

DIAGRAMA G

COEFICIENTES DE RESISTENCIA PARA PLACAS PLANAS Y LISAS

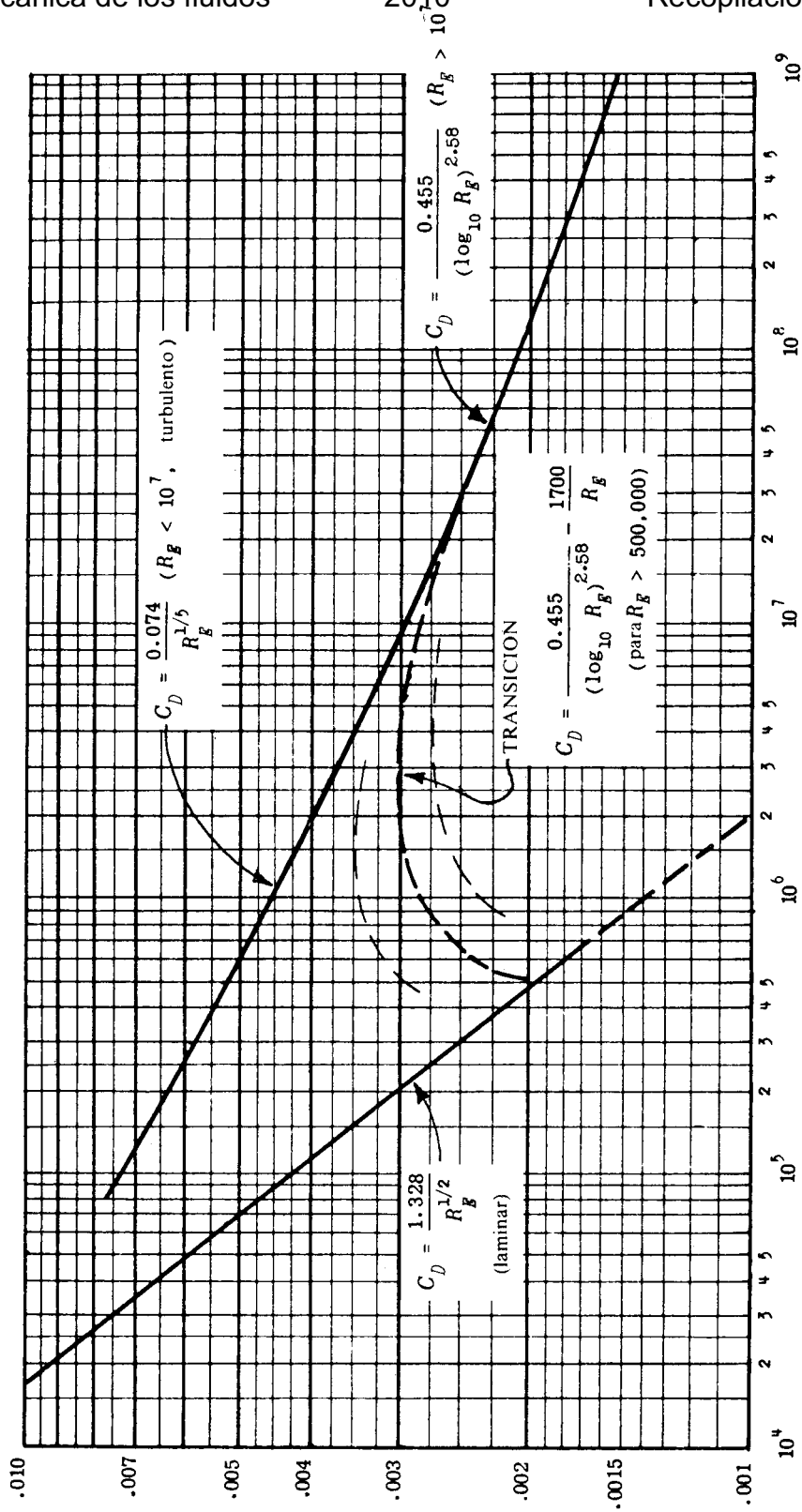

NUMERO DE REYNOLDS (Vx/ν)

DIAGRAMA H

COEFICIENTES DE RESISTENCIA A VELOCIDADES SUPERSONICAS

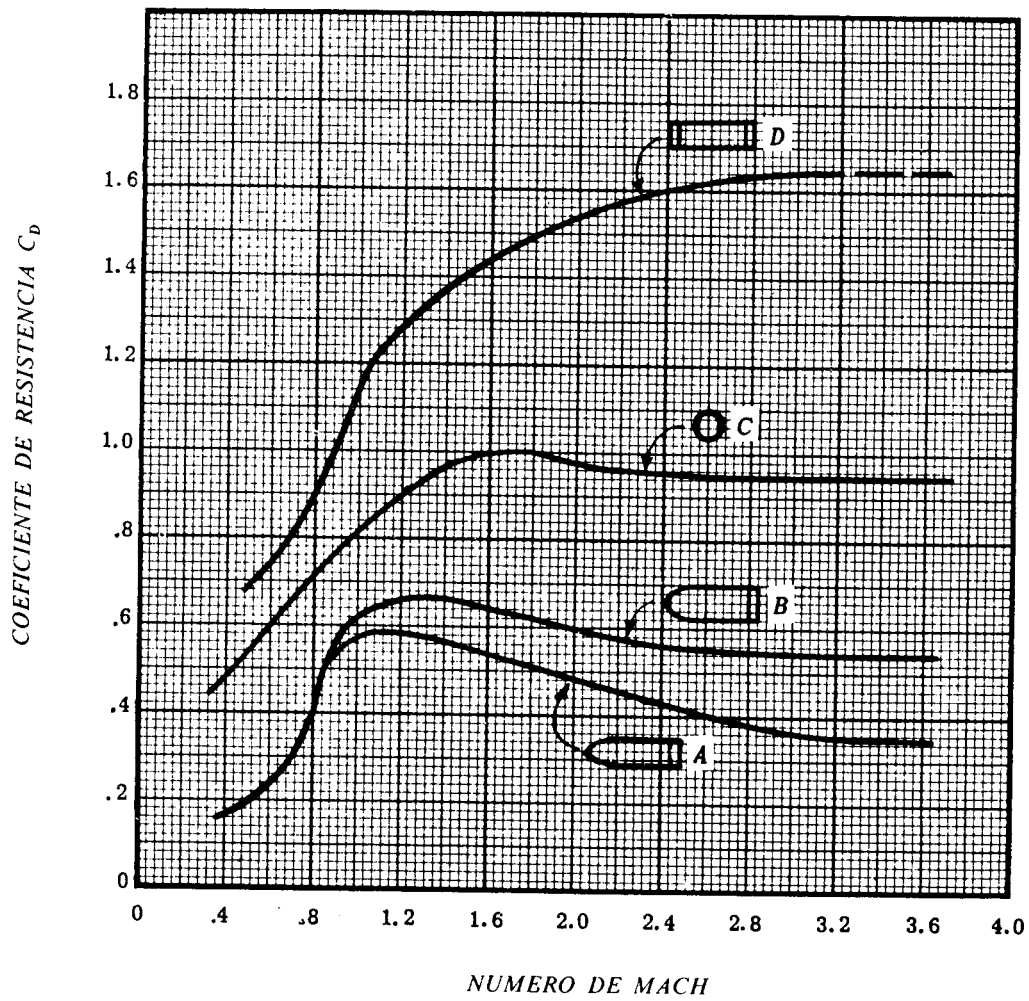

LRN - JRN

LRN - PRE-SELECTION GRAPHS

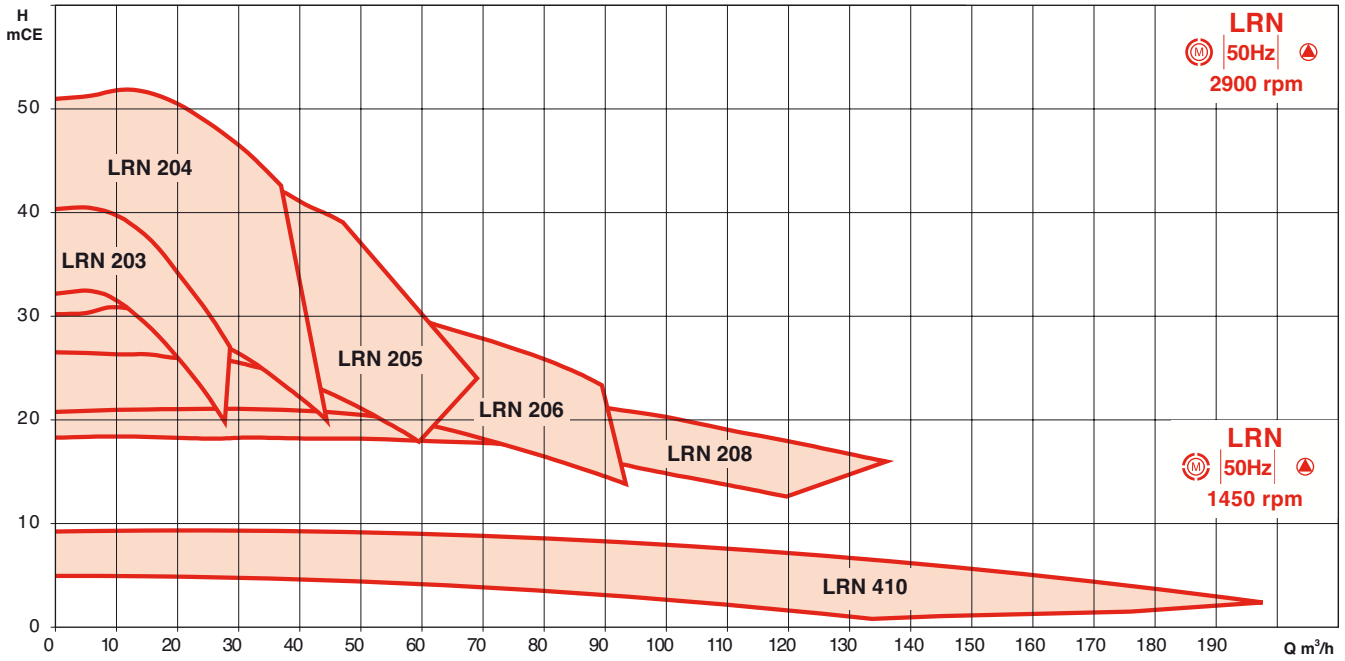

MOUNTING POSITIONS

direct mounting on vertical or horizontal pipe

Take care of the venting valve position : always on top.

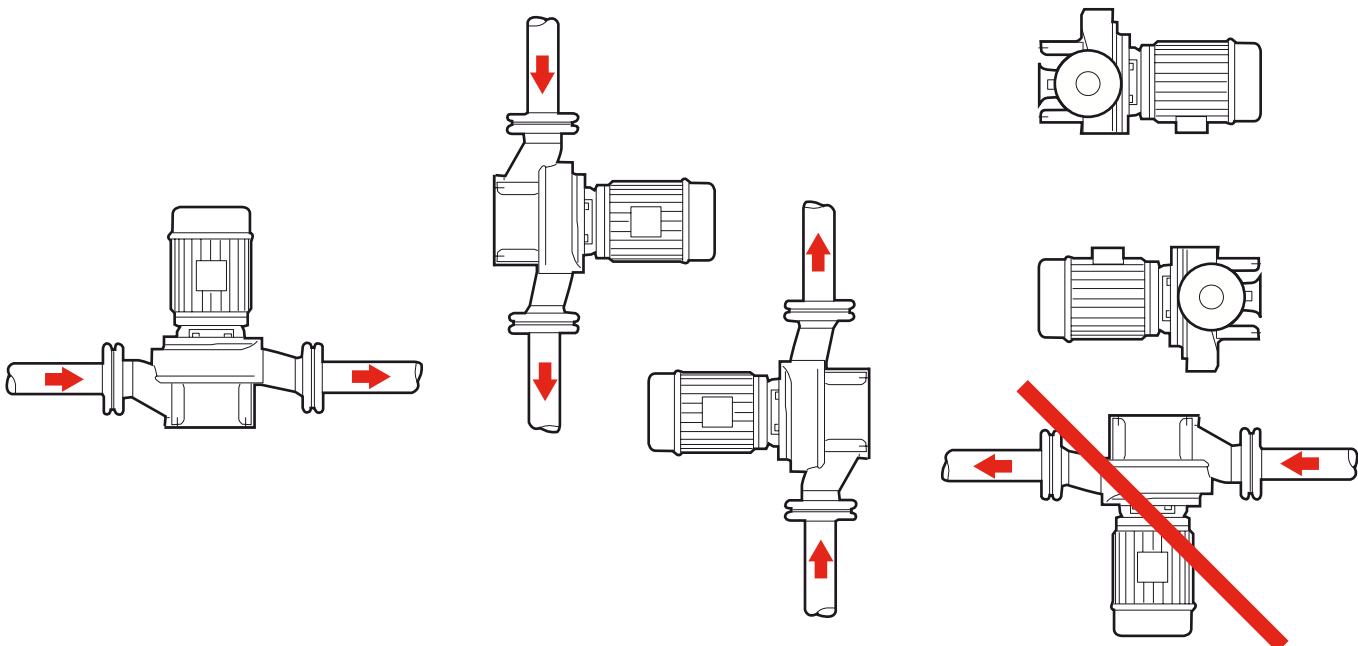

LRN - JRN

HYDRAULIC PERFORMANCE LRN 2 POLE

